

PACSystems™ RSTi-EP

FUNCTIONAL SAFETY MANUAL



Contents

Chapter 1:	Introduction	1
1.1	Revisions in this Manual	1
1.2	Module Switchable by EP-xx.....	1
Chapter 2:	Safety	3
2.1	General Safety Notice.....	3
2.1.1	Electrostatic Discharge.....	3
2.1.2	Open Equipment	3
2.1.3	Fusing	4
2.1.4	Earthing (Functional Earth FE).....	4
2.1.5	Shielding	4
2.2	Intended Use	4
2.3	Use in a Potentially Explosive Atmosphere	5
2.3.1	ATEX Zone 2.....	5
2.3.2	ATEX Marking	5
2.4	Notes on Functional Safety.....	6
2.4.1	Safety Integrity Level (SIL).....	6
2.4.2	Performance Level (PL).....	6
2.4.3	Safety Categories.....	6
2.5	Legal Notice	7
2.6	Requirements on Sensors/Signal Generators.....	7
Chapter 3:	System Overview	8
3.1	Safety Function	9
3.2	Sample Design	9
3.3	Transition.....	11
3.4	Safety Level.....	11
Chapter 4:	Configuration	12
4.1	Switch-off Delay Time.....	12
4.2	Operation with and Without Test Pulses.....	13
Chapter 5:	Detailed Descriptions of EP-19xx Modules	15
5.1	General Technical Data for EP-19xx.....	15
5.2	Data Width of EP-19xx Modules.....	16

5.3	Digital Input Module EP-1901.....	17
5.3.1	LEDs	19
5.3.2	Connection Diagrams	20
5.3.3	Specifications EP-1901	20
5.4	Digital Input Module EP-1902.....	25
5.4.1	LEDs	27
5.4.2	Connection Diagrams	27
5.4.3	Specifications EP-1902	28
5.5	Digital Input Module EP-1922.....	32
5.5.1	LEDs	34
5.5.2	Connection Diagrams	34
5.5.3	Specifications EP-1922	36
Chapter 6: Installation		41
Chapter 7: Example Applications		42
7.1	Dual-channel Emergency Stop Monitoring.....	42
7.2	Dual-channel Light Curtain Monitoring (AOPD type 4) and Emergency Stop Monitoring.....	43
7.3	Dual-channel Emergency Stop and Cable-pull Switch Monitoring	44
7.4	Dual-channel Safety Door Monitoring with Automatic Reset and Emergency Stop	45
7.5	Safety Mat	47
7.6	Dual-channel Two-hand Monitoring with Automatic Start	48
7.7	Dual-channel Safety Door Monitoring with Magnetic Switch, Automatic Reset and Emergency Stop.....	50
7.8	Dual-channel Safety Door Monitoring, Spring-operated Interlock with Manual Reset and Emergency Stop	51
7.9	Dual-channel Safety Door Monitoring, Magnetically Operated Interlock with Manual Reset and Emergency Stop	54
7.10	Dual-channel Safety Door Monitoring with Proximity Sensors, Automatic Reset and Emergency Stop.....	55
7.11	Dual-channel Safety Door Monitoring, Spring-operated Interlock, Controlled Shutdown with Manual Reset and Emergency Stop	56
7.12	Dual-channel Safety Door Monitoring with Automatic Reset and Controlled Shutdown and Emergency Stop	58
7.13	Cascading.....	59
Chapter 8: LED Indicators and Troubleshooting		61
Chapter 9: Accessories and Replacement Parts.....		64
9.1	Replacement Parts.....	64

Appendix A: Checklist for Use of EP-19xx Modules..... 65

Warning & Caution Notes as Used in this Publication



Warning

Warning notices are used in this publication to emphasize that hazardous voltages, currents, temperatures, or other conditions that could cause personal injury to exist in this equipment or may be associated with its use.

In situations where inattention could cause either personal injury or damage to equipment, a Warning notice is used.



Caution

Caution notices are used where equipment might be damaged if care is not taken.

Notes: Notes merely call attention to information that is especially significant to understanding and operating the equipment.

These instructions do not purport to cover all details or variations in equipment, nor to provide for every possible contingency to be met during installation, operation, and maintenance. The information is supplied for informational purposes only, and Emerson makes no warranty as to the accuracy of the information included herein. Changes, modifications, and/or improvements to equipment and specifications are made periodically and these changes may or may not be reflected herein. It is understood that Emerson may make changes, modifications, or improvements to the equipment referenced herein or to the document itself at any time. This document is intended for trained personnel familiar with the Emerson products referenced herein.

Emerson may have patents or pending patent applications covering subject matter in this document. The furnishing of this document does not provide any license whatsoever to any of these patents.

Emerson provides the following document and the information included therein as-is and without warranty of any kind, expressed or implied, including but not limited to any implied statutory warranty of merchantability or fitness for particular purpose.

Chapter 1: Introduction

Safety technology is of central importance in industrial automation and machine building. If you want to reduce risks and avoid dangers for people and environment, you need solutions which satisfy stringent requirements and statutory specifications. The safety modules of the RSTi-EP system have key features such as emergency-stop circuits and wire-breakage or short-circuit detection. They meet all SIL 3 requirements according to IEC 62061 and EN ISO 13849-1, category 4, PL e, and support the safe operation of your system.

By safely shutting down the downstream output modules, the safety modules attain maximum safety with optimum control. All input sensors are independently supplied via separate voltage paths and report the current machine status to the control unit. Restarting is either carried out in manual mode or using the auto start function. In addition, Emerson safety modules reduce maintenance and service times and improve response times in case of emergency – thanks to a concept of maximum transparency, for example, using OSSD outputs.

1.1 Revisions in this Manual

Rev	Date	Description
B	Sep-2019	<ul style="list-style-type: none">Following Emerson's acquisition of this product, changes have been made to apply appropriate branding and registration of the product with required certification agencies. No changes to material, process, form, fit or functionality.Added New Digital Input Negative logic module
A	Nov-2017	Added EPXMBE101 (Dual LAN Modbus Network Adapter).
-	Nov-2015	Initial Release

1.2 Module Switchable by EP-xx

Safely switchable output modules:

- EP-2214
- EP-2614
- EP-2634
- EP-2218
- EP-225F
- EP-5422
- EP-5442
- EP-4164
- EP-4264

In case a N-logic output module is positioned within a safety segment the connected load needs to be switched against +24 V Safe.

The relay output modules EP-2714 and EP-2814 are not safely switchable, therefore they must not switch any safety function.

The digital counter module EP-5111 will not be switched since it is supplied via the input current path.

Chapter 2: Safety

This section includes general safety instructions for handling the RSTi-EP system. Specific safety instructions for specific tasks and situations are given at the appropriate places in the documentation.

2.1 General Safety Notice

Work on the RSTi-EP products may only be performed by qualified electricians with the support of trained persons. As a result of their professional training and experience, an electrician is qualified to perform the necessary work and identify any potential risks.

Before any work is carried out on the products (installation, maintenance, retrofitting), the power supply must be switched off and secured against being switched on again. Work may be carried out with safety extra-low voltage.

When working during continued operations, the emergency stop mechanisms must not be made ineffective. If you need technical help, contact Technical Support. For phone numbers and email addresses, refer to the **Error! Reference source not found.** at the end of this manual.

If a malfunction on a RSTi-EP product cannot be fixed after following the recommended measures (refer to the Chapter, LED Indicators and Troubleshooting), the product in question must be sent back to Emerson. Emerson does not assume any liability if the base or electronic module has been tampered with.

2.1.1 Electrostatic Discharge

RSTi-EP products can be damaged or destroyed by electrostatic discharge. When handling the products, the necessary safety measures against electrostatic discharge (ESD) according to IEC 61340-5-1 and IEC 61340-5-2 must be observed.

All devices are supplied in ESD-protected packaging. The packing and unpacking as well as the installation and disassembly of a device may only be carried out by qualified personnel and in accordance with the ESD information.

2.1.2 Open Equipment

RSTi-EP products are open equipment that may only be installed and operated in lockable housings, cabinets or electrical operations rooms. Only trained and authorized personnel may access the equipment.

For applications requiring functional safety, the surrounding housing must meet at least IP 54.

The standards and guidelines applicable for the assembly of switch cabinets and the arrangement of data and supply lines must be complied with.

2.1.3 Fusing

If EP-190x safe power-feed modules are installed within a RSTi-EP station, a Safety Extra Low Voltage (SELV) / Protected Extra Low Voltage (PELV) power supply must be applied to ensure the safety functions.

The operator must set up the equipment so that it is protected against overloading. The upstream fuse must be designed such that it does not exceed the maximum load current. The maximum permissible load current of the RSTi-EP components can be found in the technical data.

In the case of modules without fused sensor/actuator power supplies, all lines to the connected sensors/actuators must be fused corresponding to their conductor cross-section (as per DIN VDE 0298 Part 4).

To meet UL-specifications in accordance with UL 248-14, a UL-certified automatic fuse or a 10 A fuse with a medium time-lag.

All connections of the RSTi-EP components are protected against voltage pulses and overcurrent in accordance with IEC 61131-2, Zone B. The operator must decide whether additional overvoltage protection according to IEC 62305 is required. Voltages that exceed +/-30 V may cause the destruction of Network Adapters and modules.

A feed-in power supply with secure isolation must be used.

2.1.4 Earthing (Functional Earth FE)

Each RSTi-EP I/O module is fitted with an FE spring on the underside which creates an electrical connection to the DIN rail. In order to establish a secure connection, the assembly must be carried out carefully in accordance with the instructions. The module is earthed by connecting the DIN rail to the protective earth via the earth terminal.

2.1.5 Shielding

Shielded lines are to relate to shielded plugs and fixed on a shield bus in compliance with the relevant standard.

2.2 Intended Use

The products of the RSTi-EP series are intended for use in industrial automation. A RSTi-EP station with bus Network Adapter and connected modules is intended for the decentralized control of systems or sub-systems. Through the Network Adapter, every module of a station is integrated into a fieldbus structure and connected to the control unit. The RSTi-EP products conform to protection class IP 20 (in accordance with DIN EN 60529), they can be used in potentially explosive atmospheres rated as Zone 2 (as per Directive 94/9/EC) and in safe zones.

The observance of the supplied documentation is part of the intended use. The products described in this manual may only be used for the intended applications and only in connection with certified third-party devices or components.

2.3 Use in a Potentially Explosive Atmosphere

If RSTi-EP products are used in potentially explosive atmospheres, the following notes are also applicable:

- Staff involved in assembly, installation and operation must be qualified to perform safe work on electrical systems protected against potentially explosive atmospheres.
- For applications in potentially explosive atmospheres, the requirements according to IEC/EN 60079-15 must be observed, in particular the housing enclosing the system must meet the requirements of explosion protection type Ex n or Ex e and protection class IP54.
- Sensors and actuators that are located in Zone 2 or in a safe zone can be connected to the RSTi-EP station.
- When the temperature under rated conditions exceeds 70 °C at the conductor or conduit entry point, or 80 °C at the contact, the temperature specification of the selected cable shall follow the actual measured temperature values.
- When using relay modules EP-2814 in explosive atmosphere:
 - Condensation shall be avoided.
 - If the switching voltage exceeds 63V, a surge protection device shall be provided, that limits the transients to a peak voltage of 500V or less.
- A visual inspection of the RSTi-EP station is to be performed once per year.

WARNING

- EXPLOSION HAZARD SUBSTITUTION OF COMPONENTS MAY IMPAIR SUITABILITY FOR CLASS I, DIVISION 2.
- WHEN IN HAZARDOUS LOCATIONS, TURN OFF POWER BEFORE REPLACING OR WIRING MODULES; AND
- DO NOT CONNECT OR DISCONNECT EQUIPMENT UNLESS POWER HAS BEEN SWITCHED OFF OR THE AREA IS KNOWN TO BE NONHAZARDOUS.

2.3.1 ATEX Zone 2

The module must be mounted in an enclosure certified in accordance with EN60079-15 for use in Zone 2, Group IIC and rated IP54. The enclosure shall only be able to be opened with the use of a tool.

2.3.2 ATEX Marking

 II 3 G Ex nA IIC T4 Gc

Ta: -20°C ... +60°C

2.4 Notes on Functional Safety

2.4.1 Safety Integrity Level (SIL)

The safety requirements necessary for the safety functions of an application are determined in a risk analysis. Here, the probability of failure of the safety functions is important. In an operating mode with a high rate of demand or continuous demand, the probability of dangerous failure per hour (PFH) must be taken into consideration, whereas in an operating mode with a lower rate of demand, the probability of dangerous failure on demand (PFD) must be taken into consideration.

According to IEC 61508 and IEC 62061, the safety requirements are graded by the failure limit values as follows:

Safety Requirements by Failure Limit Values

	PFD	PFH
SIL3	$< 10^{-3}$	$< 10^{-7}$
SIL2	$\geq 10^{-3}$ to $< 10^{-2}$	$\geq 10^{-7}$ to $< 10^{-6}$
SIL1	$\geq 10^{-2}$ to $< 10^{-1}$	$\geq 10^{-6}$ to $< 10^{-5}$

2.4.2 Performance Level (PL)

According to DIN EN ISO 13849-1, the degree to which a safety function contributes to risk minimization is defined as the performance level. A distinction is made between the five levels PLa to PLe with an increasing contribution to risk minimization

2.4.3 Safety Categories

Safety categories according to DIN EN ISO 13849-1 describe a minimum level of applicable safety and to what extent monitoring is required.

Category B: The safety-related components of machine controls and/or their safety equipment as well as their components must be designed, selected, assembled and combined to the state of the art such they can withstand the expected conditions.

Category 1: The requirements of Category B must be met. Use of proven safety-related components.

Category 2: The requirements of Category B must be met with the use of proven safety principles. The safety functions must be verified by the machine controls at suitable intervals (depending on the application and the type of machine).

Category 3: The requirements of Category B must be met with the use of proven safety principles. Controls must be designed so that a single failure in the control system does not lead to a loss of safety function(s), and whenever reasonably practicable, the single failure shall be detected with suitable means which meet the state of the art.

Category 4: The requirements of Category B must be met along with the use of proven safety principles. Controls must be designed so that a single failure in the control system does not lead to a loss of safety function(s), and whenever reasonably practicable, a single failure is detected

during or prior to the next demand upon the safety function, or if this is not possible, an accumulation of faults does not lead to the loss of the safety function(s).

2.5 Legal Notice

The RSTi-EP series products are CE-compliant in accordance with Directive 2004/108/EC (EMC Directive) and Directive 2006/95/EC (Low Voltage Directive). They also meet the requirements of the ATEX Directive 94/9/EC.

2.6 Requirements on Sensors/Signal Generators

The sensors/signal generators being connected must meet the following requirements:

- Only signal generators that are suited for the respective required safety level may be used.
- Positively opening control switches must be used in accordance with IEC 60947-5-1 (designated with this symbol:).
- Only use components that have been proven in operation.
- Depending on the established risk level, switches (for example, for position monitoring) may have to have a redundant design.
- Depending on the required safety level, control devices may have to have a redundant design. In this regard, make sure to consider the applicable C standards.

Chapter 3: System Overview

The RSTi-EP safe power-feed modules EP-19xx are intended for connecting safety-related equipment. The EP-19xx modules are controlled using contact-based safety transducers and/or safety transducers with OSSD inputs. The safety function consists of the safe disconnection of 24 V outputs by switching them Off when there is a safety circuit failure.

Each EP-19xx module safely switches off all following modules that are supplied by the output current path and thus creates a safety segment. A survey of the switchable modules is shown at the end of this section. The safety segment extends either to the next EP-7641 module or to the end of the station. A safety-related input circuit together with pulsed inputs is used for detecting broken wires and short circuits.

In the RSTi-EP system, three types of EP-19xx modules are available:

- EP-1901 (one safe input)
- EP-1902 (two safe inputs)
- EP-1922 (two safe inputs, delayed switching off possible)

Figure 1: Safe Power-feed Module EP-1901



Figure 2: feed Module EP-1902

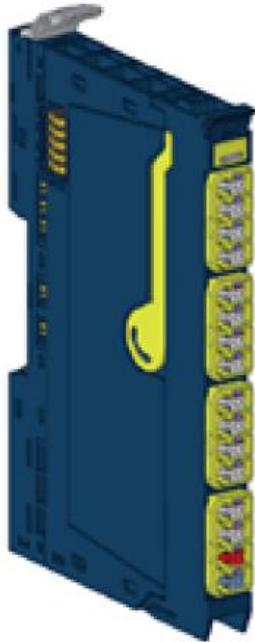

With EP-19xx modules, the following safety functions can be implemented:

- Up to two dual-channel safety circuits (AND linked), for example, for emergency stop switch, safety door contacts and safety light curtain
- A range of output modules within a RSTi-EP station is safely supplied with power via the switched 24 V Safe output.
- EP-19xx modules can be cascaded.

3.1 Safety Function

The safety function of the safe power-feed modules is that the safe output 24 V Safe is being switched according to the information of the inputs (Type 3 according to EN 61131-2, N-switching respectively). The safe status is 24 V switched off (current path for outputs and the output 24 V Safe is switched off).

3.2 Sample Design

The following figure exemplifies how to design a safety segment using an EP-19xx module. All output modules arranged within the safety segment will be switched safely. DI modules can be arranged within the safety segment, only they do not fulfill any safety function and are not influenced by the EP-19xx module.

Figure 3: Example Set-up of a Safety Segment (1) with EP-19xx

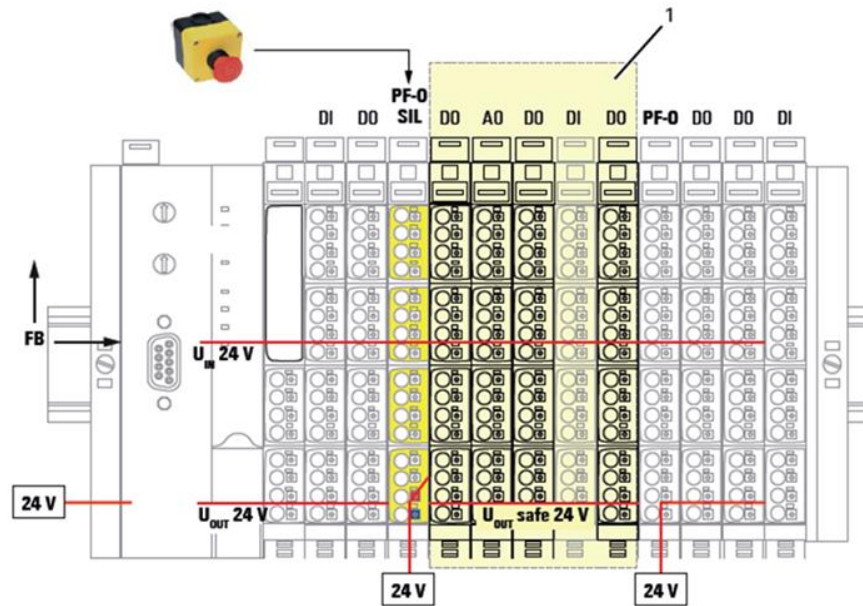

To switch the 24 V Safe voltage back on, either an automatic or a manual start can be selected.

- Automatic start: the safe output current path is switched on immediately after resetting the safety circuit(s).

⚠ WARNING

- The Automatic Start option should only be used after a risk analysis has shown that the application is suitable.
- Manual start: the output current path is only switched on again if the start button has been held down for a preset length of time.

With the delay SIL module (EP-1922) switching off can be delayed by a defined time so that, for example, a machine can be shut down in a controlled manner. The delay time can be set in four steps between 0 and 60 seconds (corresponds to stop category 1 as per EN 60204).

3.3 Transition

Figure 4: Transition Diagram

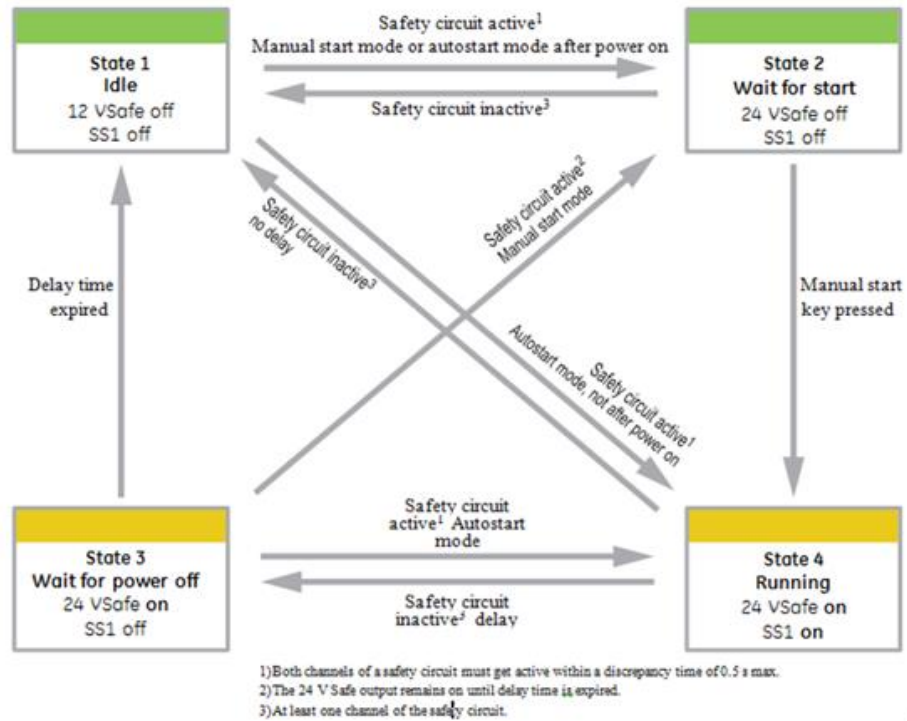

With the delay SIL module (EP-1922) switching off can be delayed by a defined time so that, for example, a machine can be shut down in a controlled manner. The delay time can be set in four steps between 0 and 60 seconds (corresponds to stop category 1 as per EN 60204).

3.4 Safety Level

Depending on the entire safety chain, the EP-19xx modules optimally achieve the following safety

- SIL3 (as per IEC 61508)
- SIL CL3 (as per IEC 62061)
- PLe (as per DIN EN ISO 13849-1)
- Cat. 4 (as per DIN EN ISO 13849y levels:

Chapter 4: Configuration

An EP-19xx module can be positioned anywhere in the RSTi-EP station. Each safety segment might include at most 12 switchable modules. Multiple EP-19xx modules and thus safety segments can be set up in a single station.

When planning a RSTi-EP station with EP-7641 modules, the following requirements must be met:

- The overall current consumption of all switchable modules within a safety segment must be lower than 100 mA (refer to the table Switch-off Delay and current Consumption).
- Each safety segment might include at most 12 switchable modules.
- The switch-off delay time (discrepancy time) for the safe input channels within a safety circuit is 500 ms ± 10 ms.
- The load output is not designed for either inductive or capacitive loads.
- The station must be safeguarded with an 8-A super-fast fuse.
- A SELV/PELV power supply must be used.
- The safely shut-off systems/applications must get their power only from the safe feed-in module EP-19xx. Likewise, it must not be possible to feed external energy into the safety segment elsewhere.
- Relay modules can be located after the safe feed-in module; however, their outputs cannot be safely shut off in case of a malfunction.
- At the SS1 output of the EP-1922, only systems/equipment that do not feed any power back into the system in the event of a malfunction can be connected.
- Any external short circuits in the wiring of the safe output must be avoided.
- Fault exclusion as per EN ISO 13849-2 must be provided.

4.1 Switch-off Delay Time

The turn-off time of an EP-19xx module is 20 ms, caused by the hardware and firmware delay time. The time required until the output voltage even of the last switchable module of a safety segment is below 5 V, can be calculated as follows:

Switch off delay [ms] = Turn-off time of an EP-19xx module + Sum of all modules' hardware delay

Switch-off Delay and Current Consumption

Module	Hardware Delay (ms)	Current Consumption (mA)
EP-2214	2	8
EP-2614	2	8
EP-2634	3	15
EP-2218	1	15
EP-225F	1	10
EP-5422	5	10
EP-5442	5	10
EP-4164	150 [†]	10
EP-4264	150 [†]	10

[†] The delay time is always 150 ms, irrespective of the amount of these modules.

4.2 Operation with and Without Test Pulses

All safe power-feed modules provide a test pulse evaluation, so that the highest safety levels can be achieved (see technical data).

Figure 5: Example of Operation with Test Pulses

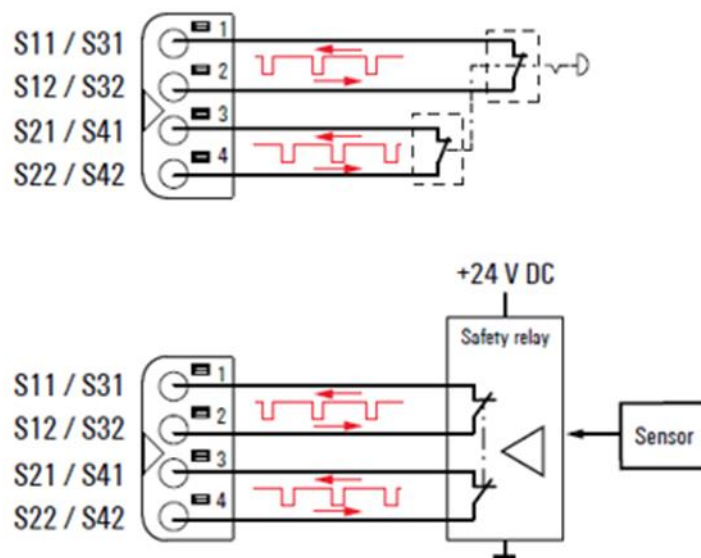

The safe power-feed module EP-1922 might also be operated without test pulses. This is mandatory whenever an external device producing own test pulses is connected. Test pulses can be enabled or disabled using the DIP-switches at the module

Figure 6: Example of Operation without Test Pulses

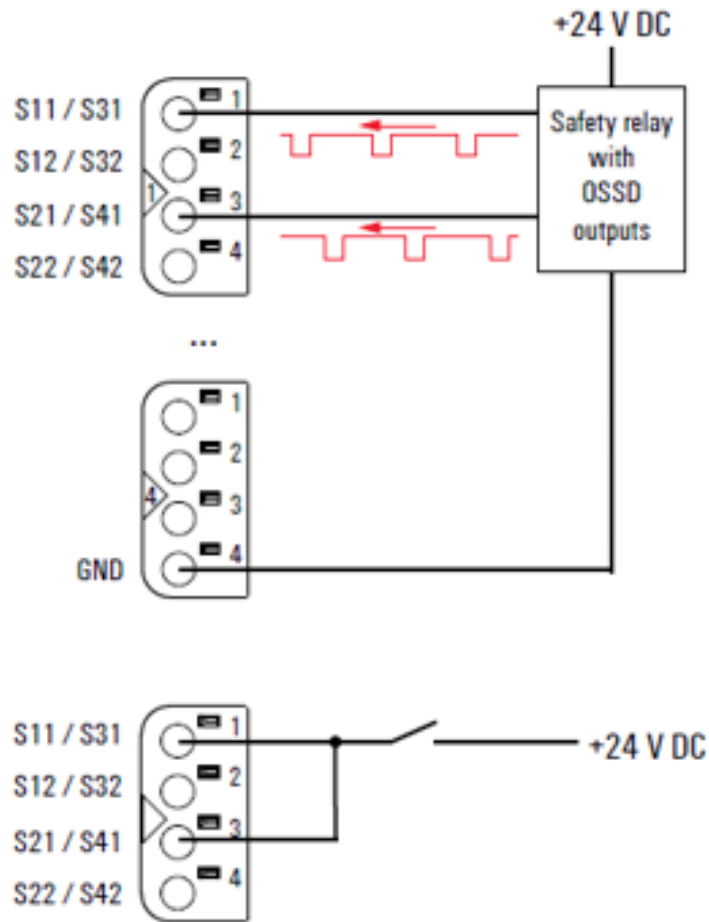

Chapter 5: Detailed Descriptions of EP-19xx Modules

5.1 General Technical Data for EP-19xx

Specification	Description	
Type of connection	Spring-style	
Line connection cross-section	Single-wired	0.14 – 1.5 mm ² (0.01 – 0.06 in ²) (AWG 26 – 16)
	Fine-wired	0.14 – 1.5 mm ² (0.01 – 0.06 in ²) (AWG 26 – 16)
Dimensions	Height	120 mm (4.72 in) (with release lever: 128 mm, 5.04 in)
	Width	11.5 mm (0.45 in)
	Depth	76 mm (2.99 in)
Weight	80 – 84 g (2.83 – 2.96 oz)	
Protection class (DIN EN 60529)	IP 20	
Flammability rating UL 94	V-0	
Temperature data	Operation	-20 to +60°C (-4 to +140 °F)
	Storage, transport	-40 to +85°C (-40 to +185 °F)
Humidity	Operation, storage, transport	5% to 95 %, non-condensing as per IEC 1131-2
Air pressure	Operation	≥ 795 hPa (altitude ≤ 2000 m, 6562 ft) as per IEC 61131-2
	Storage, transport	≥ 700 hPa (altitude ≤ 3000 m, 9843 ft) as per IEC 61131-2
Vibration resistance	5 Hz ≤ f ≤ 8.4 Hz: 3.5 mm (0.14 in) amplitude as per IEC 60068-2-6 8.4 Hz ≤ f ≤ 150 Hz: 1 g (0.04 oz) acceleration as per IEC 60068-2-6	
Shock resistance	15 g (0.5 oz) for 11 ms, half sinewave, as per IEC 60068-2-27	
Potential isolation	Test voltage	Max 28.8 V within one channel 500 V DC field/system
	Pollution severity level	2
	Overvoltage category	II
Approvals and Standards	cULus Ordinary Locations	UL 508, CSA C22.2 No. 0-M91

Specification	Description	
	cULus Hazardous Locations	ISA 12.12.01: 2007 CSA C22.2 No. 213-M1987 (Reaffirmed 2008)
	Potentially explosive atmosphere Zone 2	ATEX Directive 94/9/EC, EN 60079-0:2012 and EN 60079-15:2010
	EMC	IEC 61000 (partial standards as per the requirements of IEC 61131-2)
	PLC	IEC 61131-2
	FS	DIN EN ISO 13849-1, IEC 61508, IEC 62061
All product-specific technical data is available in the corresponding product description.		

5.2 Data Width of EP-19xx Modules

Data width of EP-19xx modules is dependent on the Network Adapter used.

Data Width

Module	Configuration	Parameter	Diagnostics	Process Data	
				Input Bytes	Output Bytes
EPXPBS001					
EPXPBS001	--	8	47	--	--
EP-1901	3	--	47	4	--
EP-1922	3	--	47	4	--
EP-1902	3	--	47	4	--
max. Data (in Byte)	244	244	244	244	244
EPXPNS001					
EPXPNS001	4	10	47	4	4
EP-1901	4	--	47	5	1
EP-1922	4	--	47	5	1
EP-1902	4	--	47	5	1
max. Data (in Byte)	260	4362	1408	512	512
EPXETC001					
EPXETC001	256	4096	3328	1024	1024
EP-1901	4	--	47	4	--
EP-1922	4	--	47	4	--
EP-1902	4	--	47	4	--

max. Data (in Byte)	1514 per telegram + CoE	1514 per telegram + CoE	1514 per telegram + CoE	1024	1024
---------------------	-------------------------	-------------------------	-------------------------	------	------

Data Width

Module	Process Data	
	Input Bytes	Output Bytes
EPXMBE001/ EPXMBE101		
EP-1901	4	--
EP-1922	4	--
EP-1902	4	--

The register structure for EPXMBE001/EPXMBE101 refer to the RSTi-EP User Manual (GFK-2958), the section Modbus® TCP Network Adapter EPXMBE001/EPXMBE101.

5.3 Digital Input Module EP-1901

Figure 7: Connection Diagram

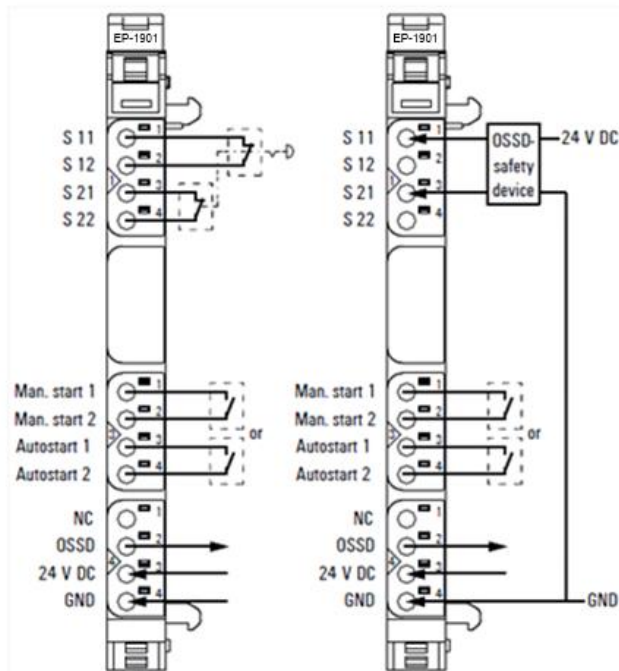

Figure 8: Safe Power-feed Module EP- 1901



The power-feed module EP-1901 enables the safe feed-in for the output current path. The module ensures that an emergency stop circuit can be monitored, and using the OSSD output it can be forwarded to a PLC or also cascaded to a further RSTi-EP station. Almost all types of output modules will be safely switched-off (SIL3/Plc/Cat. 4) when they are placed within the safety segment (refer to the last page, **Error! Reference source not found.**).

For restarting, either the manual or the auto input can be switched. In any case, the system must be reset by pressing the manual reset within 0.1 to 2 seconds after setting the supply voltage.

The evaluation of test pulses in the safety circuits provides the detection of faults or manipulations of the wiring. Therefore, every second a low pulse of 1 ms is being generated in each circuit, these pulses are phase-shifted.

The connections Safety Input 0 (S 11, S 21), Man Start 1 and Autostart 1 are digital inputs Type 3 according to EN 61131-2. The Man Start 1 input can also be controlled by a standard PLC output.

The auxiliary outputs S 12, S 22, Man Start 2 and Autostart 2 must only be used for refeeding the allocated inputs.

The maximum feed-in current in the output current path is 8 A. The module is sending a pulse (< 1 ms) every 100 ms.

⚠ CAUTION

Risk of material damage - In the case of a maximum power supply of 8 A and a maximum temperature of +60°C (+140 °F), all wired contacts on the fourth connector must be connected with 1.5 mm² (15 AWG) wiring.

5.3.1 LEDs

LED Indicators EP-1901

	Module Status	Green: Communication over the system bus
	1.1	Yellow: Safety circuit 0 OK
	1.2	--
	1.3	--
	1.4	--
	2.1	--
	2.2	--
	2.3	--
	2.4	--
	3.1	--
	3.2	--
	3.3	--
	3.4	--
	4.1	--
	4.2	Yellow: 24 V DC Safe output
	4.3	Green: Feed-in voltage in valid range
	4.4	--

For error messages, refer to the Chapter, LED Indicators and Troubleshooting.

5.3.2 Connection Diagrams

Figure 9: Block Diagram EP-1901

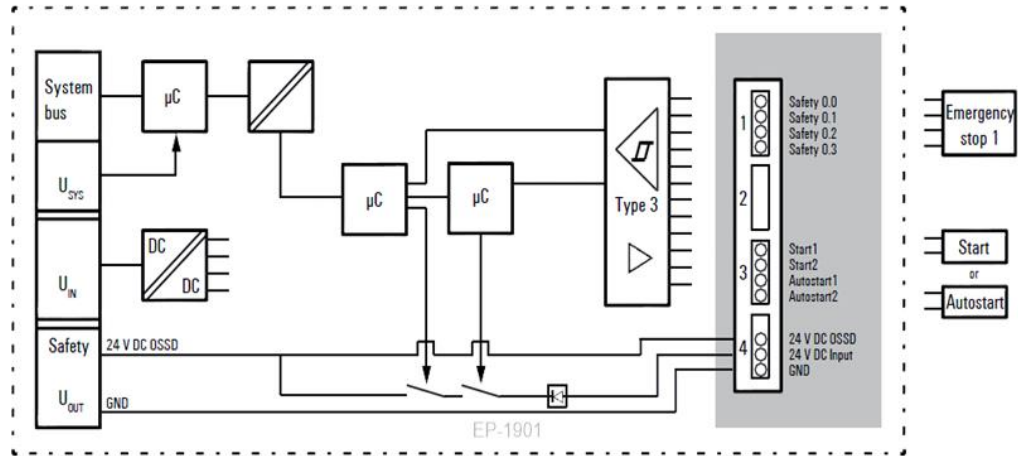

5.3.3 Specifications EP-1901

Specification	Description
System data	
Data	Process and diagnostic data depend on the network adapter used (refer to the table in the section, Data Width of EP-19xx Modules)
Interface	RSTi-EP System bus
System bus transfer rate	48 Mbps
Safety-related data per EN ISO 13849 (Regarding the entire safety chain)	
Achievable safety level	PLe and Category 4
DC (Diagnostic Coverage)	99%
MTTFd (Mean Time To Failure dangerous)	> 100 years
Safety-related data per EN 62061 (Regard the entire safety chain)	
Achievable safety level	SILCL3
PFH (Probability of Failure per Hour in 1/h)	6.27×10^{-9}
Fault reaction time	10 s
Safety-related data per EN 61508 (Regard the entire safety chain)	
Achievable safety level	SIL3
PFH (Probability of Failure per Hour in 1/h)	6.27×10^{-9}
HFT (Hardware Fault Tolerance)	1
SSF (Safe Failure Fraction)	98.58%
Presumed lifecycle time	20 years
Proof test interval	No proof test needed within the life cycle
Classification acc. To EN 61508-2:2010	Type B

Specification	Description
Inputs	
Safety inputs	1 x 2 channel
Input type	Type 3 as per IEC 61131-2
Inputs for start function	2 (manual start and autostart)
Input type	Type 3 as per IEC 61131-2
Outputs	
Safety output (OSSD)	1
Output current	8 A (not for capacitive load)
Overload protection	excess temperature proof and overload-proof, short circuit proof with external fuse
Turn-off time	< 20 ms
Turn-on time	< 2 s
Auxiliary outputs	2 x 2
Output current	max. 10 A (only to support the inputs dedicated inputs)
Diagnosis	
Module diagnosis	Yes
Individual channel diagnosis	Yes
Supply	
Supply voltage	24 V dc +20%/-15% via system bus
External pre-fusing	mandatory: super fast, max. 8 A
Reverse battery protection	Yes
Current consumption (I_{IN} in the power segment of the Network Adapter), typ.	8 mA
Current consumption (I_{IN} in the respective power segment)	45 mA
General data	
Weight	80 g (2.82 oz)
For additional general data, refer to the section, General Error! Reference source not found.	

Process Data

Byte	Bit	Description	Status
0	0	Safety input 0	0 - input inactive, 1 - input active
	1	Reserved	
	2	Auto Start	0 - inactive, 1 - active
	3	Man Start	0 - inactive, 1 - active
	4	Safety input 0 / channel 1	0 - inactive, 1 - active
	5	Safety input 0 / channel 2	0 - inactive, 1 - active
	6	Reserved	
1	0	24 V Safet Output	0 - inactive, 1 - active
	1	Reserved	

Byte	Bit	Description	Status
	2	24 V DC	0 - no feed in, 1 - power feed-in pending
	3-7	Reserved	
2	0-7	Reserved	
3	0-7	Reserved	
†Standard data format			

Diagnostic Data

Name	Bytes	Bit	Description	Default
Error indicator	0	0	Module error	
		1	Internal error	
		2	External error	
		3	Channel error	
		4	Reserved	0
		5	Power supply fault	
		6	Reserved	0
		7	0	
Module type	1	0	Module Type	0x03
		1		
		2		
		3		
		4	Channel information available	1
		5	Reserved	0
		6	Reserved	0
		7	Reserved	0
Error byte 2	2	0-7	Failure Code	
Error byte 3	3	0	Temperature Error	
		1	Internal Error	
		2	Fuse Error	
		3	Reserved	0
		4	Communication fault	
		5	Reserved	0
		6	Reserved	0
		7	Reserved	0
Channel type	4	0-6	Channel type	0x78
		7	Reserved	0
Diagnostic bits per channel	5		Number of diagnostic bits per channel	4

Name	Bytes	Bit	Description	Default
Number of channels	6		Number of similar channels per module	9
Channel error	7	0	Error at channel 0	
		1	Error at channel 1	
		2	Error at channel 2	
		3	Error at channel 3	
		4	Error at channel 4	
Error byte 3	3	0	Temperature Error	
		1	Internal Error	
		2	Fuse Error	
		3	Reserved	0
		4	Communication fault	
		5	Reserved	0
		6	Reserved	0
		7	Reserved	0
Channel type	4	0-6	Channel type	0x78
		7	Reserved	0
Diagnostic bits per channel	5		Number of diagnostic bits per channel	4
Number of channels	6		Number of similar channels per module	9
Channel error	7	0	Error at channel 0	
		1	Error at channel 1	
		2	Error at channel 2	
		3	Error at channel 3	
		4	Error at channel 4	
		5	Error at channel 5	
		6	Error at channel 6	
		7	Error at channel 7	
Channel error	8	8	Error at channel 8	
		9-15	Reserved	0
Channel error	9	16-23	Reserved	0
Channel error	10	24-31	Reserved	0
Safety 0	11	0	Input Discrepancy Error	
		1	Input Pulse Error	
		2	Input Test Error	
		3-7	Reserved	0

Name	Bytes	Bit	Description	Default
Error at channel 1	12	0-7	Reserved	0
Autostart	13	0-7	Reserved	0
Start Key	14	0-7	Reserved	0
Safety 0 Value	15	0	Input Discrepancy Error	
		1-7	Reserved	0
Error at channel 5	16	0-7	Reserved	0
SS1 Output	17	0-7	Reserved	0
OSSD Output	18	0	OSSD switch test failure	0
		1	OSSD voltage too high	
		2	OSSD voltage too low	
		3	OSSD overload	
		4-7	Reserved	0
Error at channel 9 to Error at channel 31	20-42	0-7	Reserved	0
Time stamp	43-46		Time stamp [μ s] (32 bit)	

5.4 Digital Input Module EP-1902

Figure 10: Safe Power-feed Module EP-1902



Figure 11: Connection Diagram EP-1902

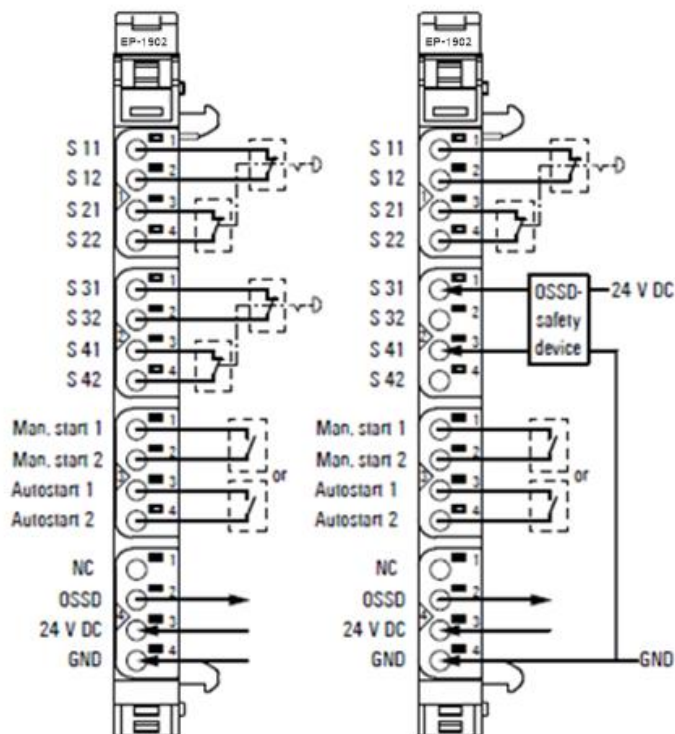

The power-feed module EP-1902 enables the safe feed-in for the output current path. The module ensures that two emergencies stop circuits can be monitored and using the OSSD output they can be forwarded to a PLC or also cascaded to a further RSTi-EP station. Almost all types of output modules will be safely switched-off (SIL3/PlE/Cat. 4) when they are placed within the safety segment (refer to the last Page, **Error! Reference source not found.**).

For restarting, either the manual or the auto input can be switched. In any case, the system must be reset by pressing the manual reset within 0.1 to 2 seconds after setting the supply voltage.

The evaluation of test pulses in the safety circuits provides the detection of faults or manipulations of the wiring. Therefore, every second a low pulse of 1 ms is being generated in each circuit, these pulses are phase-shifted.

The connections Safety Input 0 (S 11, S 21), Safety Input 1 (S 31, S 41), Man Start 1 and Autostart 1 are digital inputs Type 3 according to EN 61131-2. The Man Start 1 input can also be controlled by a standard PLC output.

The auxiliary outputs S 12, S 22, S 32, S 42, Man Start 2 and Autostart 2 must only be used for refeeding the allocated inputs.

The maximum feed-in current in the output current path is 8 A. The module is sending a pulse (< 1 ms) every 100 ms.

CAUTION

Risk of material damage - In the case of a maximum power supply of 8 A and a maximum temperature of +140 °F (+60°C), all wired contacts on the fourth connector must be connected with 1.5 mm² wiring.

5.4.1 LEDs

LED Indicators EP-1902

	Module Status	Green: Communication over the system bus
	1.1	Yellow: Safety circuit 0 OK
	1.2	--
	1.3	--
	1.4	--
	2.1	Yellow: Safety circuit 1 OK
	2.2	--
	2.3	--
	2.4	--
	3.1	--
	3.2	--
	3.3	--
	3.4	--
	4.1	--
	4.2	Yellow: 24 V Safe output active
	4.3	Green: Feed-in voltage in valid range
4.4	--	

For error messages, refer to the Chapter, LED Indicators and Troubleshooting.

5.4.2 Connection Diagrams

Figure 12: Block Diagram EP-1902

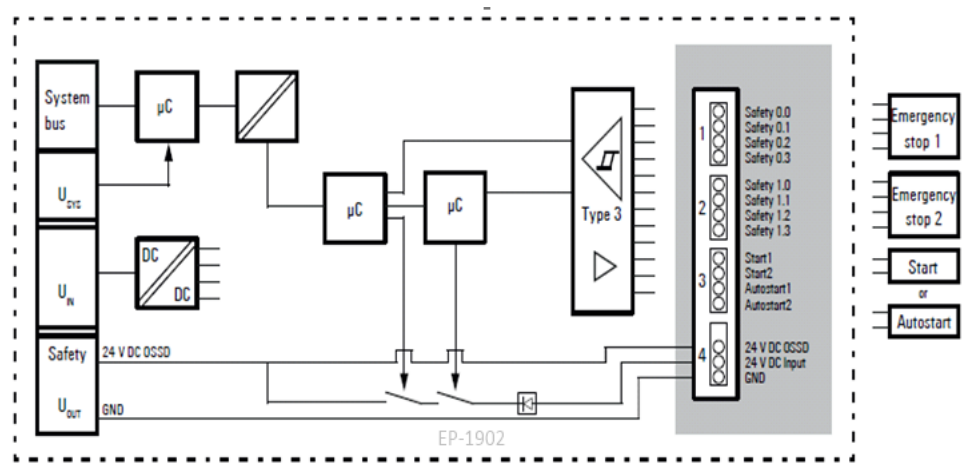

5.4.3 Specifications EP-1902

Technical Data

Specification	Description
System data	
Data	Process and diagnostic data depend on the network adapter used (refer to the table in the section, Data Width of EP-19xx Modules)
Interface	RSTi-EP I/O communication bus
System bus transfer rate	48 Mbps
Safety-related data per EN ISO 13849 (Regard the entire safety chain)	
Achievable safety level	PLe and Category 4
DC (Diagnostic Coverage)	99%
MTTFd (Mean Time To Failure dangerous)	> 100 years
Safety-related data per EN 62061 (Regard the entire safety chain)	
Achievable safety level	SILCL3
PFH (Probability of Failure in 1/h)	6.27×10^{-9}
Fault reaction time	10 s
Safety-related data per EN 61508 (Regard the entire safety chain)	
Achievable safety level	SIL3
PFH (Probability of Failure in 1/h)	6.27×10^{-9}
HFT (Hardware Fault Tolerance)	1
SSF (Safe Failure Fraction)	98.58%
Presumed lifecycle time	20 years
Proof test interval	No proof test needed within the lifecycle
Classification acc. To EN 61508-2:2010	Type B
Inputs	
Safety inputs	2 x 2 channel
Input type	Type 3 as per IEC 61131-2
Inputs for start function	2 (manual start and autostart)
Input type	Type 3 as per IEC 61131-2
Outputs	
Safety output (OSSD)	1
Output current	8 A (not for capacitive load)
Overload protection	excess temperature proof and overload-proof, short circuit proof with external fuse
Turn-off time	20 ms

Specification	Description
Turn-on time	< 2 s
Auxiliary outputs	3 x 2
Output current	max. 10 A (only to support the inputs dedicated inputs)
Diagnosis	
Module diagnosis	Yes
Individual channel diagnosis	Yes
Supply	
Supply voltage	24 V dc +20%/-15% via system bus
External pre-fusing	mandatory: super fast, max. 8 A
Reverse battery protection	Yes
Current consumption (I _{IN} in the power segment of the Network Adapter), typ.	8 mA
Current consumption (I _{IN} in the respective power segment)	45 mA
General data	
Weight	82 g (2.89 oz)
For additional general data, refer to the section, Error! Reference source not found.	

Process Data†

Byte	Bit	Description	Status
0	0	Safety input 0	0 - inactive, 1 - active
	1	Safety input 1	0 - inactive, 1 - active
	2	Auto Start	0 - inactive, 1 - active
	3	Man Start	0 - inactive, 1 - active
	4	Safety input 0 / channel 1	0 - inactive, 1 - active
	5	Safety input 0 / channel 2	0 - inactive, 1 - active
	6	Safety input 1 / channel 1	0 - inactive, 1 - active
	7	Safety input 1 / channel 2	0 - inactive, 1 - active
1	0	24 V Safe Output	0 - inactive, 1 - active
	1	Reserved	
	2	24 V DC	0 - no power feed, 1 - power feed-in pending
	3-7	Reserved	
2	0-7	Reserved	
3	0-7	Reserved	
†Standard data format			

Diagnostic Data

Name	Bytes	Bit	Description	Default
Error indicator	0	0	Module error	

Name	Bytes	Bit	Description	Default
		1	Internal error	
		2	External error	
		3	Channel error	
		4	Reserved	0
		5	Power supply fault	
		6	Reserved	0
		7	Parameter error	0
Module type	1	0	Module Type	0x03
		1		
		2		
		3		
		4	Channel information available	1
		5	Reserved	0
		6	Reserved	0
Error byte 2	2	0	Failure Code	
		7	Reserved	0
Error byte 3	3	0	Temperature Error	
		1	Internal Error (self-test, LDO, etc)	
		2	Reserved	0
		3	Internal diagnostic FIFO full	0
		4	Power supply fault	
		5	Reserved	0
		6	Process alarm lost	0
Channel type	4	0-6	Channel type	0x78
		7	Reserved	0
Channel error	7	0	Error at channel 0	
		1	Error at channel 1	
		2	Error at channel 2	
		3	Error at channel 3	
		4	Error at channel 4	
		5	Error at channel 5	
		6	Error at channel 6	
Channel error	8	8	Error at channel 8	
		9-15	Reserved	0
Channel error	9	16-23	Reserved	0
Channel error	10	24-31	Reserved	0
Safety 0	11	0	Input Discrepancy Error	

Name	Bytes	Bit	Description	Default
		1	Input Pulse Error	
		2	Input Test Error	
		3-7	Reserved	0
Safety 1	12	0	Input Discrepancy Error	
		1	Input Pulse Error	
		2	Input Test Error	
		3-7	Reserved	0
Autostart	13	0-7	Reserved	0
Start Key	14	0-7	Reserved	0
Safety 0 Value	15	0	Input Discrepancy Error	
		1-7	Reserved	0
Safety 1 Value	16	0	Input Discrepancy Error	
		1-7	Reserved	0
SS1 Output	17	0-7	Reserved	0
OSSD Output	18	0	OSSD switch test failure	0
		1	OSSD voltage too high	
		2	OSSD voltage too low	
		3	OSSD overload	
		4-7	Reserved	0
Error at channel 9 to Error at channel 31	20-42	0-7	Reserved	0
Time stamp	43-46		Time stamp [μ s] (32 bit)	

5.5 Digital Input Module EP-1922

Figure 13: Safe Power-feed Module EP-1922

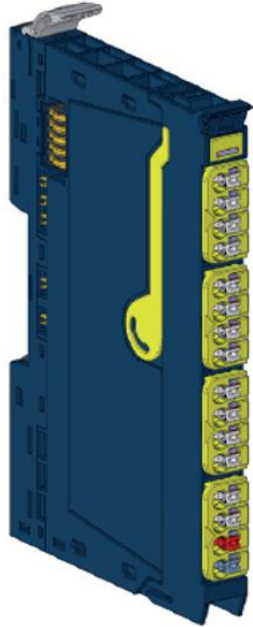
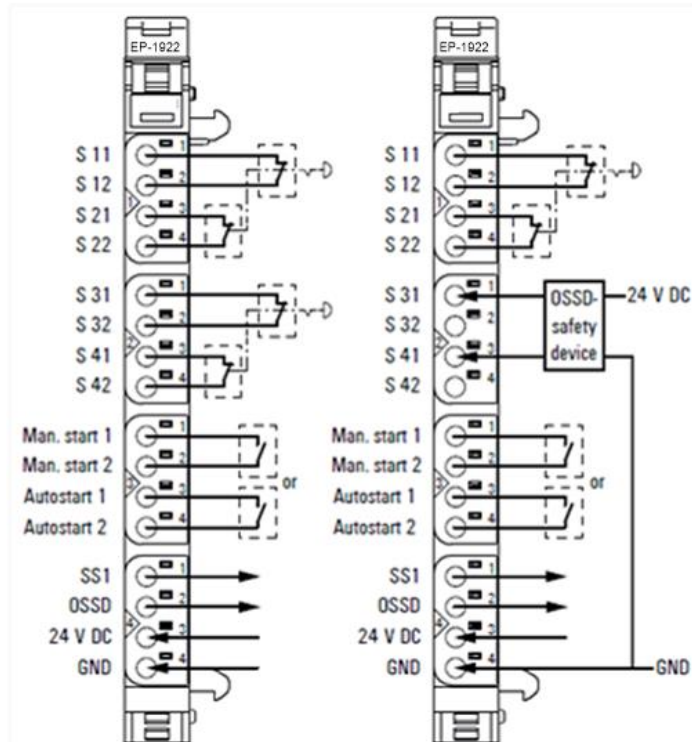

Figure 14: Connection Diagram EP-1922



The power-feed module EP-1922 enables the safe feed-in for the output current path. The module ensures that two emergencies stop circuits can be monitored and using the OSSD output they can be forwarded to a PLC or also cascaded to a further RSTi-EP station. The switch-off delay can be set using DIP switches. The un delayed status is displayed with the SS1 output. Almost all types of output modules will be safely switched-off (SIL3/Ple/Cat. 4) when they are placed within the safety segment (refer to the last page, **Error! Reference source not found.**).

For restarting, either the manual or the auto input can be switched. In any case, the system must be reset by pressing the manual reset within 0.1 to 2 s after setting the supply voltage.

The evaluation of test pulses in the safety circuits provides the detection of faults or manipulations of the wiring. Therefore, every second a low pulse of 1 ms is being generated in each circuit, these pulses are phase-shifted. The evaluation of the test pulses can be activated or deactivated by setting DIP-switches.

The connections Safety Input 0 (S 11, S 21), Safety Input 1 (S 31, S 41), Man Start 1 and Autostart 1 are digital inputs Type 3 according to EN 61131-2. The Man Start 1 input can also be controlled by a standard PLC output.

Safety sensors with OSSD outputs or standard PLC outputs can be connected if the safety inputs are used in mode "no test pulses". In this case another safety review is obligatory. The auxiliary outputs S 12, S 22, S 32, S 42, Man Start 2 and Autostart 2 must only be used for refeeding the allocated inputs.

In the case that several EP-19xx modules are used in cascades please regard that the triggering of a EP-19xx module will switch off the power supply of all subsequent power-feed modules. A delay of these modules is no longer effective. The maximum feed-in current in the output current path is 8 A. The module is sending a pulse (< 1 ms) every 100 ms.

CAUTION

Risk of material damage - In the case of a maximum power supply of 8 A and a maximum temperature of +140 °F (+60 °C), all wired contacts on the fourth connector must be connected with 1.5 mm² wiring.

5.5.1 LEDs

LED Indicators EP-1922

	Module Status	Green: Communication over the system bus
	1.1	Yellow: Safety circuit 0 OK
	1.2	--
	1.3	--
	1.4	--
	2.1	Yellow: Safety circuit 1 OK
	2.2	--
	2.3	--
	2.4	--
	3.1	--
	3.2	--
	3.3	--
	3.4	--
	4.1	Yellow: SS1 output active
	4.2	Yellow: 24 V Safe output active
	4.3	Green: Feed-in voltage in valid range
	4.4	--

5.5.2 Connection Diagrams

Figure 15: Block Diagram EP-1922

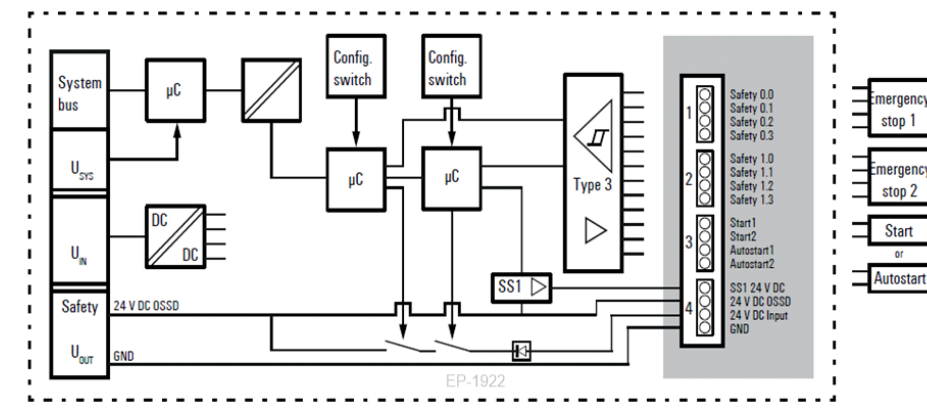

Figure 16: DIP Switch on the EP-1922

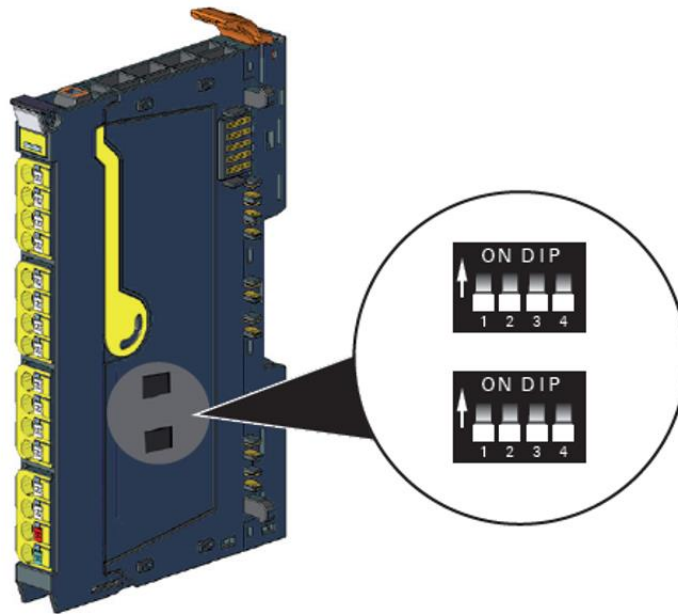













Figure 17: Setting Options for DIP Switch

Input		Delay		Function
1	2	3	4	
	X	X	X	Safety input 0 evaluating own test pulses
	X	X	X	Safety input 0 no test pulses
X		X	X	Safety input 1 evaluating own test pulses
X		X	X	Safety input 1 no test pulses
X	X			24 V Safe: no delay
X	X			24 V Safe: delay 1 second
X	X			24 V Safe: delay 30 seconds
X	X			24 V Safe: delay 60 seconds

 - ON
 - OFF

⚠ CAUTION

To ensure the safety functions, regard the following instructions for adjustment:

- DIP switches of equal numbers must have identical positions in both rows.
- If an external device generating pulses is connected to a safety input of the EP-1922 module, this input must be operatized in mode “no test pulses” (DIP switch setting ON).
- When operating in mode “no test pulses”:
 - Test pulses of the external device must be shorter than 2 ms, otherwise the safe output will be deactivated.
 - Safe laying of cables can be necessary depending on the required safety level

Note: Use something such as a ball-point pen to set the DIP switches and avoid spiked or sharp-edged tools.

5.5.3 Specifications EP-1922

Specification	Description
System data	
Data	Process and diagnostic data depend on the network adapter used (refer to the table in the section, Data Width of EP-19xx Modules)
Interface	RSTi-EP system bus
System bus transfer rate	48 Mbps
Safety-related data per EN ISO 13849 (Regard the entire safety chain)	
Achievable safety level	PLe and Cat. 4
DC (Diagnostic Coverage)	99%
MTTFd (Mean Time To Failure dangerous)	> 100 years
Safety-related data per EN 62061 (Regard the entire safety chain)	
Achievable safety level	SILCL3
PFH (Probability of Failure in 1/h)	6.27 x 10 ⁻⁹
Fault reaction time	10 s
Safety-related data per EN 61508 (Regard the entire safety chain)	
Achievable safety level	SIL3
PFH (Probability of Failure per Hour)	6.27 x 10 ⁻⁹
HFT (Hardware Fault Tolerance)	1
SSF (Safe Failure Fraction)	98.58%

Specification	Description
Presumed lifecycle time	20 years
Proof test interval	No proof test needed within the life cycle
Classification acc. To EN 61508-2:2010	Type B
Inputs	
Safety inputs	2 x 2 channel
Input type	Type 3 as per IEC 61131-2
Inputs for start function	2 (manual start and auto start)
Input type	Type 3 as per IEC 61131-2
Outputs	
Safety output (OSSD)	1
Output current	8 A (not for capacitive load)
Overload protection	excess temperature proof and overload-proof, short circuit proof with external fuse
Turn-off time	20 ms
Turn-on time	< 2 s
Output SS1	1
Output current	0.5 A, overload behavior as per IEC 61131-2
Overload protection	excess temperature proof and overload-proof, short circuit proof with external fuse
Auxiliary outputs	3 x 2
Output current	max. 10 A (only to support the inputs dedicated inputs)
Diagnosis	
Module diagnosis	Yes
Individual channel diagnosis	Yes
Supply	
Supply voltage	20.4V – 28.8V
External pre-fusing	mandatory: super-fast, max. 8 A
Reverse battery protection	Yes
Current consumption from system current path ISYS	8 mA
Current consumption from input current path IIN	45 mA
General data	
Weight	84 g (2.96 oz)
For additional general data, refer to the last page, Error! Reference source not found..	

Process Data

Byte	Bit	Description	Status
0	0	Safety input 0	0 - inactive, 1 - active
	1	Safety input 1	0 - inactive, 1 - active
	2	Auto Start	0 - inactive, 1 - active
	3	Man Start	0 - inactive, 1 - active
	4	Safety input 0 / channel 1	0 - inactive, 1 - active
	5	Safety input 0 / channel 2	0 - inactive, 1 - active
	6	Safety input 1 / channel 1	0 - inactive, 1 - active
	7	Safety input 1 / channel 2	0 - inactive, 1 - active
1	0	24 V Safe Output	0 - inactive, 1 - active
	1	SS1 Output	0 - inactive, 1 - active
	2	24 V DC	0 - no feed-in, 1 - power feed-in pending
	3-7	Reserved	
2	0-7	Reserved	
3	0	DIP-Switch Config	Safety Input 0 - Pulse, 1 - No Pulse
	1	DIP-Switch Config	Safety Input 0 - Pulse, 1 - No Pulse
	2	DIP-Switch Config	24 V Safe Output 00 - No delay, 01 - Delay 1s, 10 - Delay 30s, 11 - Delay 60s
	3	DIP-Switch Config	24 V Safe Output 00 - No delay, 01 - Delay 1s, 10 - Delay 30s, 11 - Delay 60s
	4-7	Reserved	
†Standard data format			

Diagnostic Data EP-1922

Name	Bytes	Bit	Description	Default	
Error indicator	0	0	Module error		
		1	Internal error		
		2	External error		
		3	Channel error		
		4	Reserved	0	
		5	Power supply fault		
		6	Reserved	0	
		7	Parameter error	0	
Module type	1	0	Module Type	0x03	
		1			
		2			
		3			
		4	Channel information available		1
		5	Reserved		0

Name	Bytes	Bit	Description	Default
		6	Reserved	0
		7	Reserved	0
Error byte 2	2	0	Failure Code	0
Error byte 3	3	0	Temperature Error	
		1	Internal Error	
		2	Fuse Error	0
		3	Reserved	0
		4	Communication fault	
		5	Reserved	0
		6	Reserved	0
Channel type	4	0-6	Channel type	0x78
		7	Reserved	0
Diagnostic bits per channel	5		Number of diagnostic bits per channel	4
Number of channels	6		Number of similar channels per module	11
Channel error	7	0	Error at channel 0	
		1	Error at channel 1	
		2	Error at channel 2	
		3	Error at channel 3	
		4	Error at channel 4	
		5	Error at channel 5	
		6	Error at channel 6	
		7	Error at channel 7	

Diagnostic Data

Name	Bytes	Bit	Description	Default
Channel error	8	8	Error at channel 8	
		9	Error at channel 9	
		10	Error at channel 10	
		11-15	Reserved	0
Channel error	9	16-23	Reserved	0
Channel error	10	24-31	Reserved	0
Safety 0	11	0	Input Discrepancy Error	
		1	Input Pulse Error	
		2	Input Test Error	
		3-7	Reserved	0
Safety 1	12	0	Input Discrepancy Error	
		1	Input Pulse Error	

Name	Bytes	Bit	Description	Default
		2	Input Test Error	
		3-7	Reserved	0
Autostart	13	0-7	Reserved	0
Start Key	14	0-7	Reserved	0
Safety 0 Value	15	0	Input Discrepancy Error	
		1-7	Reserved	0
Safety 1 Value	16	0	Input Discrepancy Error	
		1-7	Reserved	0
SS1 Output	17	0-7	Reserved	0
OSSD Output	18	0	OSSD switch test failure	0
		1	OSSD voltage too high	
		2	OSSD voltage too low	
		3	OSSD overload	
		4-7	Reserved	0
Error at channel 9	20	0-7	Reserved	0
Error at channel 10	21	0	DIP switch configuration	0
		1-7	Reserved	0
Config Switch	22	0	Reserved	0
		1-7	Reserved	0
Error at channel 12 to Error at channel 31	23-42	0-7	Reserved	0
Time stamp	43-46		Time stamp [μ s] (32 bit)	

Chapter 6: Installation

WARNING

Explosion risk - During assembly work, sparks can form, and surfaces may become excessively hot.

- Before assembly, make sure that there is not a potentially explosive atmosphere.
 - For applications in potentially explosive atmospheres, observe the installation and construction requirements of EN 60079- 15 and/or country-specific regulations.
-

WARNING

Dangerous contact voltage:

- Carry out assembly and wiring work on the RSTi-EP station only when the power supply is disconnected.
 - Make sure that the place of installation (switch cabinet etc.) has been disconnected from the power supply.
-

CAUTION

The product can be destroyed by electrostatic discharge.

The components in the RSTi-EP series can be destroyed by electrostatic discharge.

- Ensure that personnel and work equipment are adequately grounded.
-

Carry out all work during the installation/removal and replacement of components as described in the RSTi-EP User Manual (GFK-2958) manual.

When using EP-19xx modules, observe the following additional notes:

- EP-19xx modules may only be installed in switch cabinets which meet protection class IP 54.
 - Use wire-end ferrules in combination with flexible/multi-conductor cables.
 - Ensure that external short circuits due to the cabling cannot occur for safety inputs in the configuration without test pulses (refer to DIN EN ISO 13849-2 Table D.4).
-

Note: *Once an electronic unit is removed from a power-feed module, the inputs and outputs of the following modules are no longer supplied with power. With EP-19xx modules, this is equivalent to triggering the connected safety equipment.*

Chapter 7: Example Applications

7.1 Dual-channel Emergency Stop Monitoring

Achievable safety rating	Cat. 4	DIN EN ISO 13849-1
	PLe	DIN EN ISO 13849-1
	SIL3	IEC 62061/61508
Stop category	0	EN 60204-1
Features	Dual-channel monitoring Cross-connection detection Manual reset Monitoring of external contactors (EDM)	
Safety sensor/operating mechanism	Emergency stop button	
Notes	Autostart is possible if the NC circuits from K3 and K4 are attached to 3.3 and 3.4.	

Note: All example applications shown are proposals without warranty. In any case the operator must perform a safety review of the entire site.

When the emergency stop button is pushed, the EP-19xx switches off the 24-V supply for the modules (refer to the last page, **Error! Reference source not found.**) within the safety segment and thus also contactors K3 and K4. The failure of a switching element in the emergency stop button or a cross-circuit in its supply lines does not result in the failure of the emergency stop mechanism and is detected within the fault-reaction time.

The EP-19xx switches on the 24-V supply for the modules within the safety segment if:

- the emergency button is unlocked
- and the feedback circuit (NC contacts of K3 and K4) is closed
- and the start push button has been pushed and released again.

Contactors K3 and K4 are controlled by the PLC and can switch on as soon as the EP-19xx has switched on the 24-V supply.

Figure 18: Example Application for Dual-channel Emergency Stop Monitoring

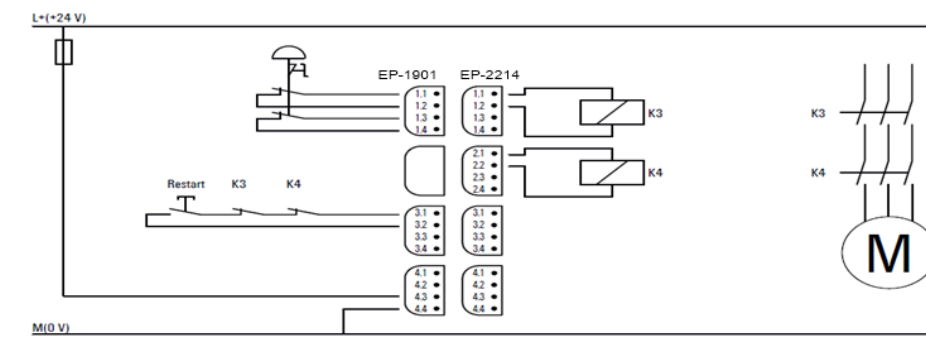

Dual-channel Light Curtain Monitoring (AOPD type 4) and Emergency Stop Monitoring

Achievable safety rating	Cat. 4	DIN EN ISO 13849-1
	PLe	DIN EN ISO 13849-1
	SIL3	IEC 62061/61508
Stop category	0	EN 60204-1
Features	Dual-channel monitoring Cross-connection detection Monitoring of external contactors (EDM) Self-test of the OSSD in the AOPD	
Safety sensor/operating mechanism	Emergency stop button AOPD type 4 (2 semiconductor outputs, p-switched)	
Notes	Autostart is possible if the NC circuits from K3 and K4 are attached to 3.3 and 3.4.	

Note: All example applications shown are proposals without warranty. In any case the operator has to perform a safety review of the entire site.

When the emergency stop button is pushed or the active optoelectronic protective device (AOPD) reacts, the EP-19xx switches off the 24-V supply for the modules (switchable modules refer to the section, **Error! Reference source not found.**) within the safety segment and thus also for contactors K3 and K4. The failure of a switching element in the emergency stop button or the AOPD as well as a cross-circuit in their supply lines does not result in the failure of the corresponding safety device and is detected within the fault-reaction time. For this purpose, the AOPD must generate a test pulse on its safety outputs at least once per second.

When using a EP-1922: If the DIP switch which is assigned to the corresponding safety circuit is switched on (in the example DIP switch 2 for LC1) so that an AOPD can be connected without test pulses, it might be necessary to have a shielded cable installation and cross-circuit fault detection via the AOPD, depending on the required safety level.

The EP-19xx switches on the 24-V supply for the modules within the safety segment if:

- Emergency button is unlocked
- Active optoelectronic protective device (AOPD) is free
- Feedback circuit (NC contacts of K3 and K4) is closed
- Start push button has been pushed and released again

Contactors K3 and K4 are controlled by the PLC and can switch on as soon as the EP-19xx has switched on the 24-V supply.

Figure 19: Example Application for Dual-channel Light Curtain Monitoring (AOPD type 4)

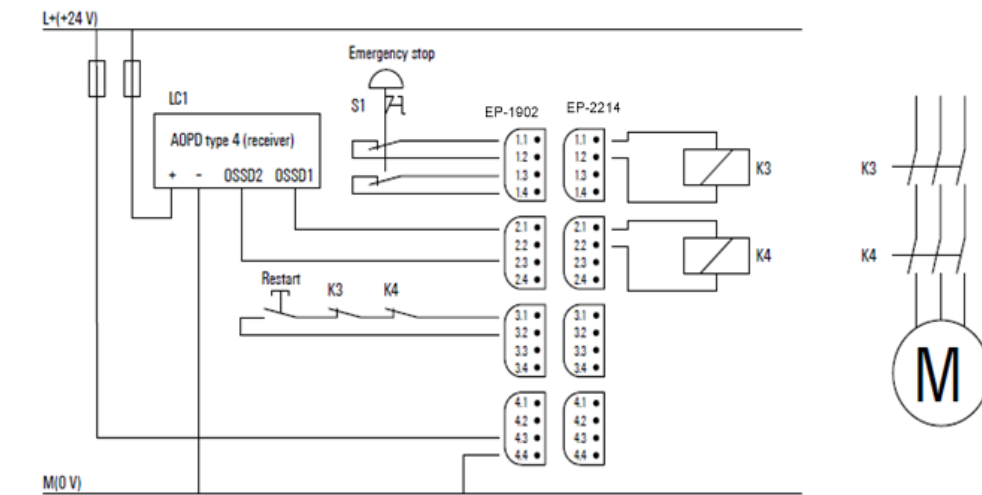

7.2 Dual-channel Emergency Stop and Cable-pull Switch Monitoring

Achievable safety rating	Cat. 4	DIN EN ISO 13849-1
	PLe	DIN EN ISO 13849-1
	SIL3	IEC 62061/61508
Stop category	0	EN 60204-1
Features	<ul style="list-style-type: none"> • Dual-channel monitoring • Cross-connection detection • Start button • Monitoring of external contactors (EDM) 	
Safety sensor/operating mechanism	<ul style="list-style-type: none"> • Emergency stop button • Cable-pull switch, latching 	
Notes	<ul style="list-style-type: none"> • Manual reset • Autostart is possible if the NC circuits from K3 and K4 are attached to 3.3 and 3.4. 	

Note: All example applications shown are proposals without warranty. In any case the operator has to perform a safety review of the entire site.

When the emergency stop button is pushed or the cable-pull switch is activated, the EP-19xx switches off the 24 V supply for the modules (switchable modules refer to the last page, **Error! Reference source not found.**) within the safety segment and thus also contactors K3 and K4. The failure of a switching element in the emergency stop button or the cable-pull switch as well as a cross-circuit in their supply lines does not result in the failure of the emergency stop mechanism and is detected within the fault-reaction time.

The EP-19xx module switches on the 24-V supply for the modules within the safety segment if:

- Emergency button is unlocked

- Cable-pull switch is unlocked
- Feedback circuit (NC contacts of K3 and K4) is closed
- Start push button has been pushed and released again

Contactors K3 and K4 are controlled by the PLC and can switch on as soon as the EP-19xx has switched on the 24-V supply.

Figure 20: Example Application for Dual-channel Emergency Stop and Cable-pull Switch Monitoring

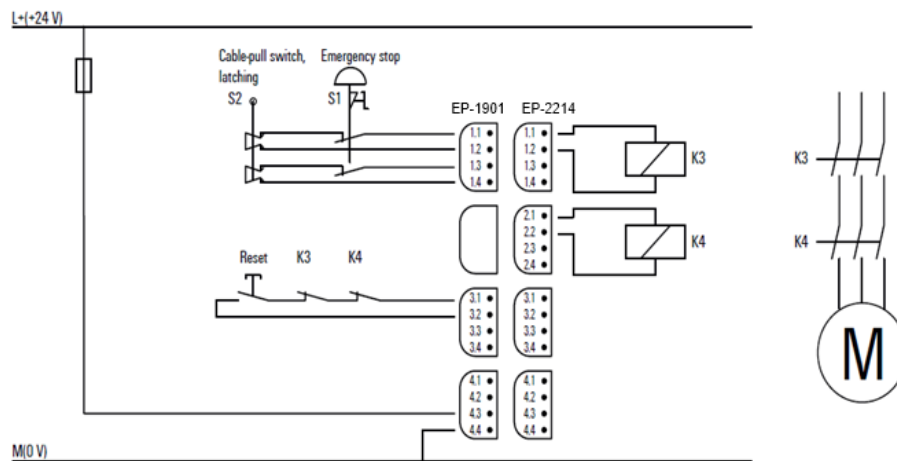

7.3 Dual-channel Safety Door Monitoring with Automatic Reset and Emergency Stop

Achievable safety rating	Cat. 4	DIN EN ISO 13849-1
	PLe	DIN EN ISO 13849-1
	SIL3	IEC 62061/61508
Stop category	0	EN 60204-1
Features	Dual-channel monitoring Cross-connection detection Automatic reset Monitoring of external contactors (EDM)	
Safety sensor/operating mechanism	Emergency stop button Position switch	
Notes	The application must be compatible with the automatic start-up function.	

Note: All example applications shown are proposals without warranty. In any case the operator has to perform a safety review of the entire site.

When the emergency stop button is pushed or the safety door is opened, the EP-19xx switches off the 24-V supply for the modules (switchable modules refer to the last page, **Error! Reference**

source not found.) within the safety segment and thus also contactors K3 and K4. The failure of a switching element in the emergency stop button or the safety door contacts as well as a cross-circuit in their supply lines does not result in the failure of the emergency stop mechanism and is detected within the fault-reaction time.

The EP-19xx switches on the 24-V supply for the following modules* within the safety segment if:

- Emergency button is unlocked
- Safety door is closed
- Feedback circuit (NC contacts of K3 and K4) is closed

Contactors K3 and K4 are controlled by the PLC and can switch on as soon as the EP-19xx module has switched on the 24-V supply. To reset the system, press the reset button within 0.1 to 2 sec after switching on the power supply, even when automatic reset is used.

Figure 21: Example Application for Dual-channel Safety Door Monitoring with Automatic Reset & Emergency Stop

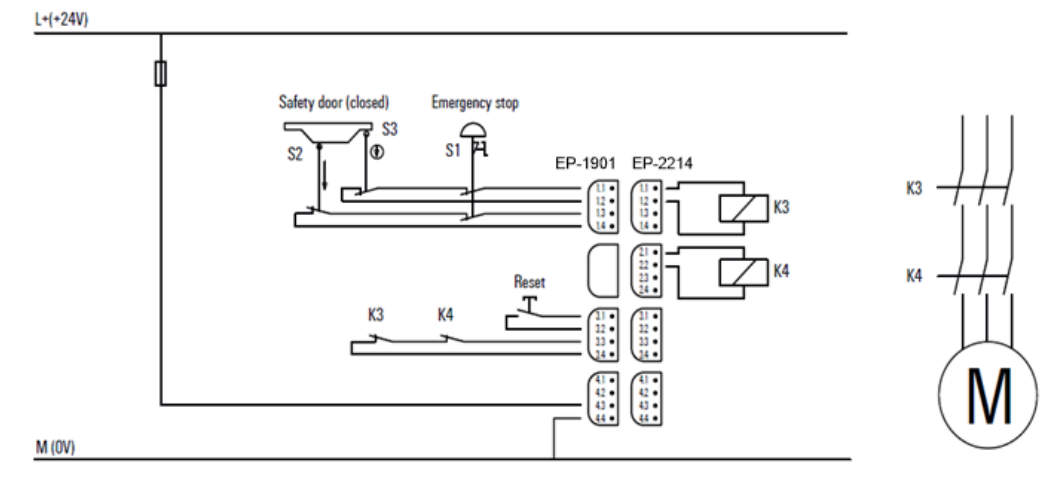

7.4 Safety Mat

Achievable safety rating	Cat. 4	DIN EN ISO 13849-1
	PLe	DIN EN ISO 13849-1
	SIL3	IEC 62061/61508
Stop category	0	EN 60204-1
Features	Single-channel monitoring Cross-connection detection Wire break detection Monitoring of external contactors (EDM)	
Safety sensor/operating mechanism	Safety mat	
Notes	Manual reset Observe EN 1760-1 and EN ISO 13856-1 The same interface is also possible for pressure-sensitive buffers and pressure-sensitive strips; however, check the safety ratings during use K5: Weidmüller RCIKIT(Z) 24 V DC 2CO LD/FG (connect the coil connection at the EP-1922 to 4.1 instead of to 4.2)	

Note: All example applications shown are proposals without warranty. In any case the operator has to perform a safety review of the entire site.

When the safety mat is stepped on, the EP-19xx switches off the 24-V supply for the modules (switchable modules refer to the section, **Error! Reference source not found.**) within the safety segment and thus also contactors K3 and K4. An interruption or a cross-connection in the supply lines for the safety mat do not result in the failure of the safety function and is detected within before the next starting cycle.

As an alternative to both NC contacts for the reset switch, a NO contact can be used there. One of its contacts is set at M (0 V) and the other contact is wired through a diode to connection 1.1 and through a diode to connection 1.3 (both cathodes to the switch).

The EP-19xx switches on the 24-V supply for modules within the safety segment if:

- Safety mat has not been actuated
- Feedback circuit (NC contacts of K3 and K4) is closed
- Start push button has been pushed and released again.

Contactors K3 and K4 are controlled by the PLC and can switch on as soon as the EP-19xx has switched on the 24-V supply. To reset the system, press the reset button within 0.1 to 2 sec after switching on the power supply, even when automatic reset is used.

Combined with a safety mat EP-19xx modules attain safety rating Cat. 3 only.

Figure 22: Example Application for Safety Mat

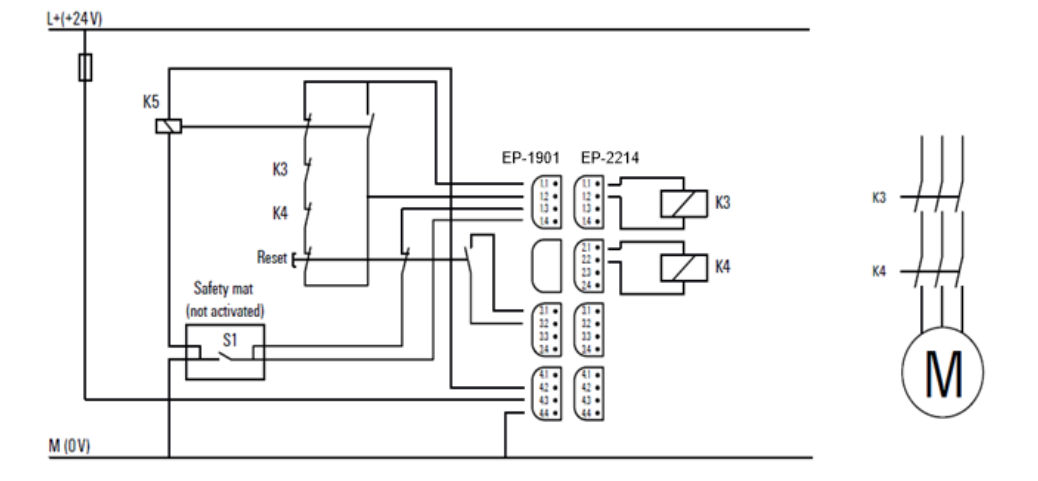

7.5 Dual-channel Two-hand Monitoring with Automatic Start

Achievable safety rating	Cat. 4	DIN EN ISO 13849-1
	PLe	DIN EN ISO 13849-1
	SIL3	IEC 62061/61508
Stop category	0	EN 60204-1
Features	Dual-channel monitoring Cross-connection detection Automatic reset Monitoring of external contactors (EDM)	
Safety sensor/operating mechanism	Two-hand switch	
Notes	The application must be compatible with the automatic start-up function.	

Note: All example applications shown are proposals without warranty. In any case the operator has to perform a safety review of the entire site.

If one or both switches of the 2-hand switch are released, the EP-19xx switches off the 24-V supply for the modules (switchable modules refer to the last page, **Error! Reference source not found.**) inside the safety segment and thus also for contactors K3 and K4. The failure of a switching element in the two-hand switch or a cross-circuit in its supply lines does not result in the failure of the emergency stop mechanism and is detected within the fault-reaction time. An interruption of the NC contact by S2 is detected before the next switching cycle and by S1 when the power is switched on.

The EP-19xx module switches on the 24-V supply for the following modules within the safety segment if:

- Two-hand switch is pressed synchronously within 0,5 seconds

- Feedback circuit (NC contacts of K3 and K4) is closed

Contactors K3 and K4 are controlled by the PLC and can switch on as soon as the EP-19xx has switched on the 24-V supply. To reset the system, press the reset button within 0.1 to 2 sec after switching on the power supply, even when automatic reset is used.

Figure 23: Example Application for Dual-channel Two-hand Monitoring with Automatic Start

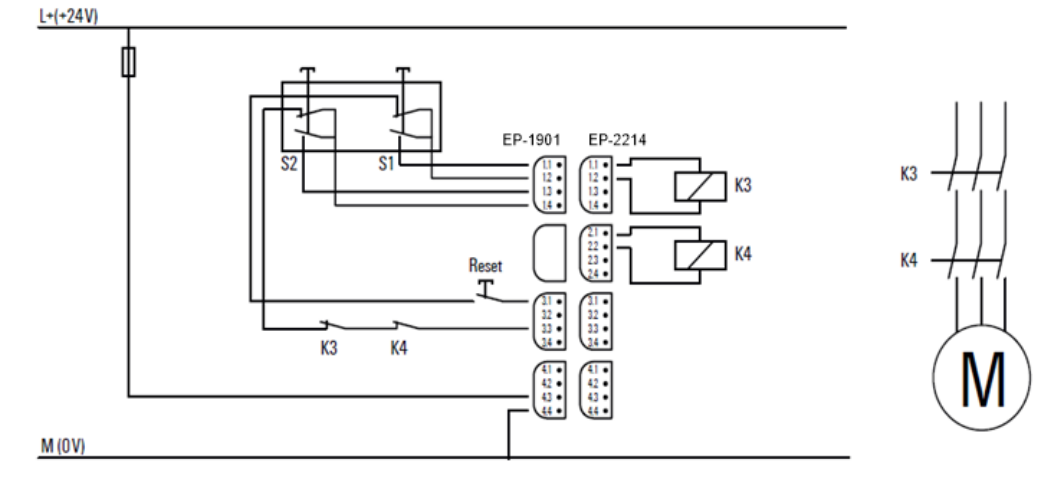

7.6 Dual-channel Safety Door Monitoring with Magnetic Switch, Automatic Reset and Emergency Stop

Achievable safety rating	Cat. 4	DIN EN ISO 13849-1
	PLe	DIN EN ISO 13849-1
	SIL3	IEC 62061/61508
Stop category	0	EN 60204-1
Features	Dual-channel monitoring PDF-M (as per EN 60947-5-3) Cross-connection detection Automatic reset Monitoring of external contactors (EDM)	
Safety sensor/operating mechanism	Emergency stop button Magnetic switch with coded magnet	
Notes	The application must be compatible with the automatic start-up function.	

Note: *All example applications shown are proposals without warranty. In any case the operator must perform a safety review of the entire site.*

When the emergency stop button is pushed or the safety door is opened, the EP-19xx switches off the 24-V supply for the modules (switchable modules refer to the last page, **Error! Reference source not found.**) within the safety segment and thus also contactors K3 and K4. The failure of a switching element in the emergency stop button or the safety door as well as a cross-circuit in their supply lines does not result in the failure of the emergency stop mechanism and is detected within the fault-reaction time.

The EP-19xx switches on the 24-V supply for the modules within the safety segment if:

- Emergency stop button is unlocked
- Safety door is closed
- Feedback circuit (NC contacts of K3 and K4) is closed

Contactors K3 and K4 are controlled by the PLC and can switch on as soon as the EP-19xx has switched on the 24-V supply. To reset the system, press the reset button within 0.1 to 2 s after switching on the power supply, even when automatic reset is used.

Figure 24: Example Application for Dual-channel Safety Door Monitoring with Magnetic Switch, Automatic Reset and Emergency Stop

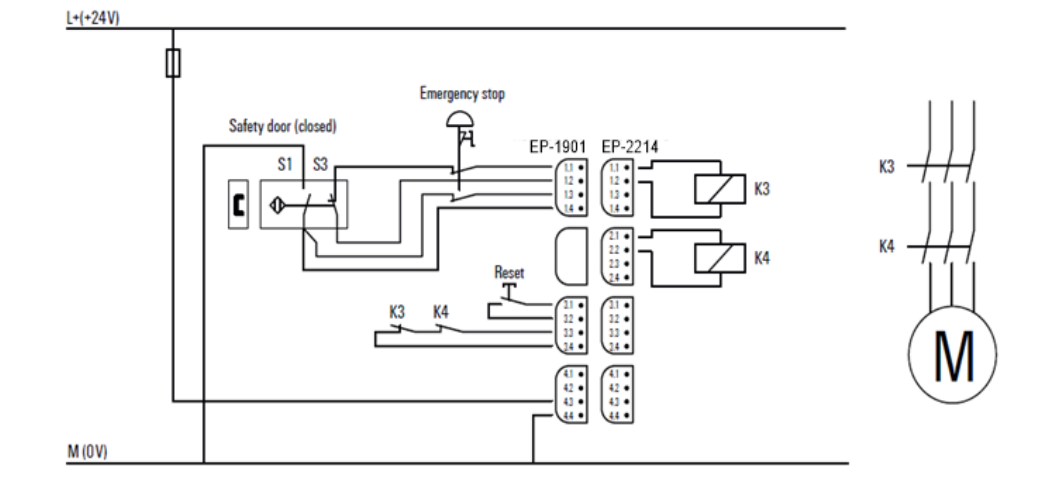

7.7 Dual-channel Safety Door Monitoring, Spring-operated Interlock with Manual Reset and Emergency Stop

Achievable safety rating	Cat. 4	DIN EN ISO 13849-1
	PLe	DIN EN ISO 13849-1
	SIL3	IEC 62061/61508
Stop category	0	EN 60204-1
Features	<ul style="list-style-type: none"> • Dual-channel monitoring • Cross-connection detection • Manual reset • Monitoring of external contactors (EDM) 	
Safety sensor/operating mechanism	<ul style="list-style-type: none"> • Emergency stop button • Position switch with interlock • Zero-speed monitor • Manual unlocking 	
Notes	Exclusion of the fault Interruption or releasing of the activator, error in the safety interlock	

Note: All example applications shown are proposals without warranty. In any case the operator has to perform a safety review of the entire site.

When the emergency stop button is pushed, the EP-19xx switches off the 24-V supply for the modules (switchable modules refer to the section, **Error! Reference source not found.**) within the safety segment and thus also contactors K3 and K4. The failure of a switching element in the emergency stop button or the safety door contact as well as a cross-circuit in their supply lines

does not result in the failure of the emergency stop mechanism and is detected within the fault-reaction time.

A stop is performed by switching off K3 and K4 via the PLC. After the motor comes to a stop, as observed by the zero-speed monitor, the spring-operated interlock can be activated via the unlocking button and the safety door can be opened. When the power supply is turned off, the safety door cannot be opened if the locking mechanism is engaged. We recommend using switches with mechanical unlocking capabilities.

The EP-19xx switches on the 24-V supply for the following modules within the safety segment if:

- Emergency stop button is unlocked
- Safety door is closed
- Locking mechanism is engaged
- Feedback circuit (NC contacts of K3 and K4) is closed
- Start push button has been pushed and released again

Contactors K3 and K4 are controlled by the PLC and can switch on as soon as the EP-19xx has switched on the 24-V supply.

Figure 25: Example Application for Dual-channel Emergency Stop Monitoring

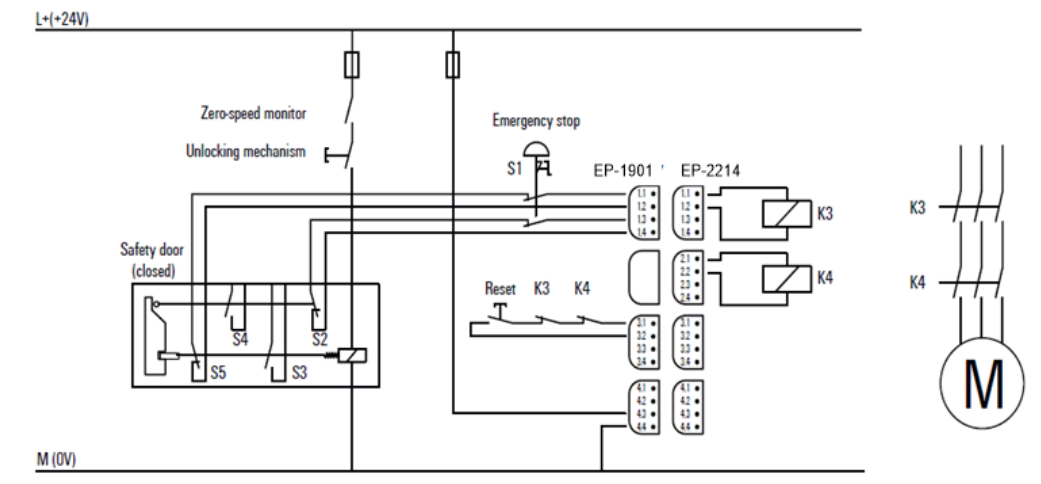

7.8 Dual-channel Safety Door Monitoring, Magnetically Operated Interlock with Manual Reset and Emergency Stop

Achievable safety rating	Cat. 4	DIN EN ISO 13849-1
	PLe	DIN EN ISO 13849-1
	SIL3	IEC 62061/61508
Stop category	0	EN 60204-1
Features	<ul style="list-style-type: none"> • Dual-channel monitoring • Cross-connection detection • Automatic reset • Monitoring of external contactors (EDM) • Off-delay via PLC 	
Safety sensor/operating mechanism	<ul style="list-style-type: none"> • Emergency stop button • Position switch with interlock 	
Notes	<ul style="list-style-type: none"> • Exclusion of the fault Interruption or releasing of the activator, error in the safety interlock • The PLC must activate the interlock directly after the safety door is closed 	

Note: *All example applications shown are proposals without warranty. In any case the operator has to perform a safety review of the entire site.*

When the emergency stop button is pushed, the EP-19xx switches off the 24-V supply for the modules (switchable modules refer to the section, **Error! Reference source not found.**) within the safety segment and thus also contactors K3 and K4. The failure of a switching element in the emergency stop button or the safety door contact as well as a cross-circuit in their supply lines does not result in the failure of the emergency stop mechanism and is detected within the fault-reaction time.

A stop is performed by switching off K3 and K4 via the PLC. The door can be opened when the PLC releases the interlock.

The EP-19xx switches on the 24-V supply for modules within the safety segment if

- Emergency button is unlocked
- Safety door is closed
- PLC has activated and engaged the interlock
- Feedback circuit (NC contacts of K3 and K4) is closed
- Start push button has been pushed and released again

Contactors K3 and K4 are controlled by the PLC and can switch on as soon as the EP-19xx has switched on the 24-V supply.

Figure 26: Example Application for Dual-channel Safety Door Monitoring, Magnetically Operated Interlock with Manual Reset, Stop and Emergency Stop

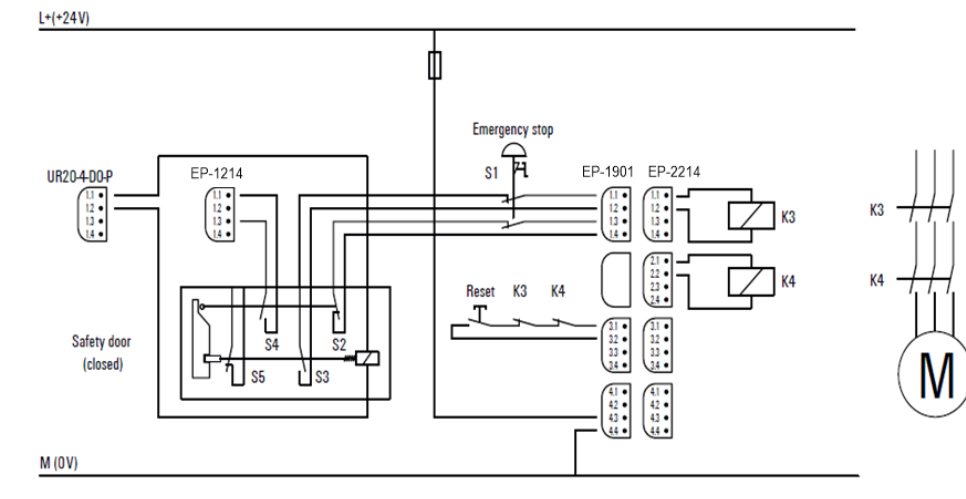

7.9 Dual-channel Safety Door Monitoring with Proximity Sensors, Automatic Reset and Emergency Stop

Achievable safety rating	Cat. 4	DIN EN ISO 13849-1
	PLe	DIN EN ISO 13849-1
	SIL3	IEC 62061/61508
Stop category	0	EN 60204-1
Features	<ul style="list-style-type: none"> • Dual-channel monitoring • Cross-connection detection • Automatic reset • Monitoring of external contactors (EDM) 	
Safety sensor/operating mechanism	<ul style="list-style-type: none"> • Emergency stop button • 2 proximity switches 	
Notes	<p>The power supply for the proximity switches is not shown</p> <p>The application must be compatible with the automatic start-up function</p>	

Note: All example applications shown are proposals without warranty. In any case the operator has to perform a safety review of the entire site.

If the emergency stop button is pushed or at least one magnetic switch is opened, the EP-19xx switches off the 24-V supply for the modules within safety segment and thus also contactors K3 and K4. The failure of a switching element in the emergency stop button or a cross-circuit in its supply lines does not result in the failure of the emergency stop mechanism and is detected within the fault-reaction time.

The EP-19xx switches on the 24-V supply for modules within the safety segment if:

- Emergency button is unlocked
- Both magnetic contacts are closed
- Feedback circuit (NC contacts of K3 and K4) is closed

Contactors K3 and K4 are controlled by the PLC and can switch on as soon as the EP-19xx has switched on the 24-V supply. To reset the system, press the reset button within 0.1 to 2 s after switching on the power supply, even when automatic reset is used.

Figure 27: Example Application for Dual-channel Safety Door Monitoring with Proximity Detectors, Automatic Reset and Emergency Stop

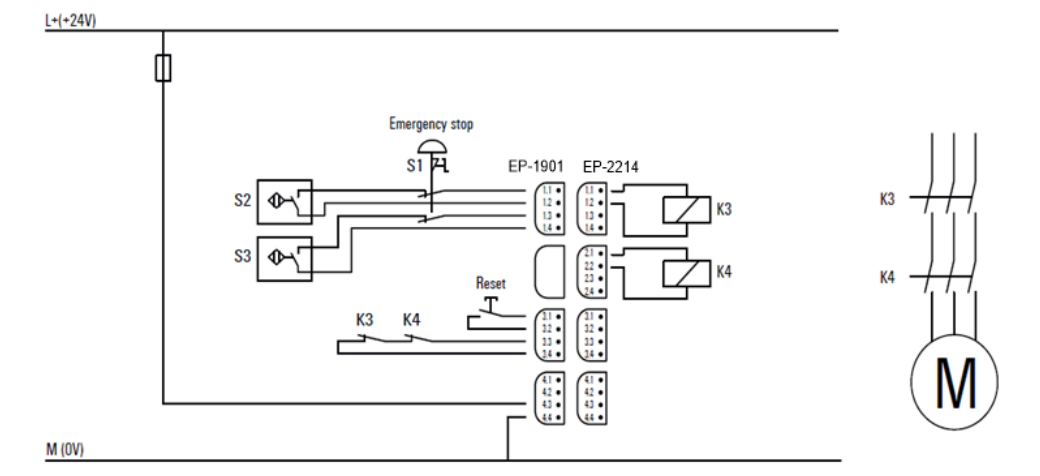

7.10 Dual-channel Safety Door Monitoring, Spring-operated Interlock, Controlled Shutdown with Manual Reset and Emergency Stop

Achievable safety rating	Cat. 4	DIN EN ISO 13849-1
	PLe	DIN EN ISO 13849-1
	SIL3	IEC 62061/61508
Stop category	0	EN 60204-1
Features	Dual-channel monitoring Cross-connection detection Manual reset Monitoring of external contactors (EDM)	
Safety sensor/operating mechanism	Emergency stop button Position switch with interlock Manual unlocking	
Notes	Exclusion of the fault Interruption or releasing of the activator, error in the safety interlock	

	As soon as the enabling on the frequency converter is withdrawn, the converter must execute a controlled shutdown
--	---

Note: All example applications shown are proposals without warranty. In any case the operator must perform a safety review of the entire site.

When the emergency stop button is pushed, the EP-19xx switches off the 24-V supply for the modules (switchable modules refer to the last page, **Error! Reference source not found.**) within the safety segment and thus also contactors K3 and K4. The failure of a switching element in the emergency stop button or the safety door contact as well as a cross-circuit in their supply lines does not result in the failure of the emergency stop mechanism and is detected within the fault-reaction time.

After pressing the stop button and the delay time set in the EP-1922, the spring-operated interlock can be activated with the unlock button and the safety door can be opened. When the power supply is turned off, the safety door cannot be opened if the locking mechanism is engaged. We recommend using switches with mechanical unlocking capabilities.

The EP-19xx switches on the 24-V supply for modules within the safety segment if:

- Emergency button is unlocked
- Safety door is closed
- Locking mechanism is engaged
- Feedback circuit (NC contacts of K3 and K4) is closed
- Start push button has been pushed and released again

Contactors K3 and K4 are controlled by the PLC and can switch on as soon as the EP-19xx has switched on the 24-V supply.

Figure 28: Example Application for Dual-channel Safety Door Monitoring, Spring-operated Interlock, Controlled Shutdown with Manual Reset and Emergency Stop

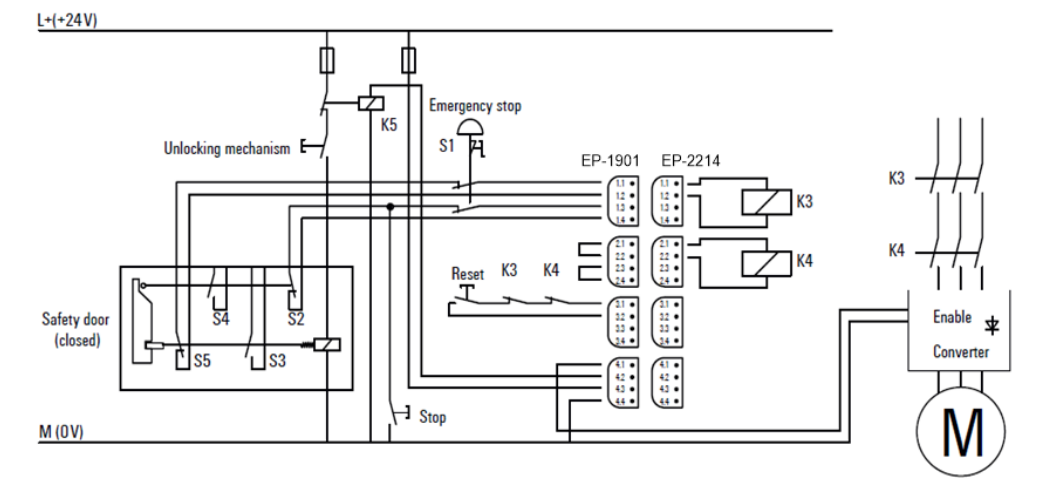

7.11 Dual-channel Safety Door Monitoring with Automatic Reset and Controlled Shutdown and Emergency Stop

Achievable safety rating	Cat. 4	DIN EN ISO 13849-1
	PLe	DIN EN ISO 13849-1
	SIL3	IEC 62061/61508
Stop category	0	EN 60204-1
Features	Dual-channel monitoring Cross-connection detection Automatic reset Monitoring of external contactors (EDM)	
Safety sensor/operating mechanism	Emergency stop button Position switch Optional: brake	
Notes	Autostart is also possible if the NC circuits from K3 and K4 are connected to 3.3 and 3.4 As soon as the enabling on the frequency converter is withdrawn, the converter must execute a controlled shutdown Exclusion of fault: No external energy might be fed into the control line of the brake (such as caused by cable fault)	

Note: *All example applications shown are proposals without warranty. In any case the operator must perform a safety review of the entire site.*

When the emergency stop button is pushed, the EP-19xx switches off the 24-V supply for the modules (switchable modules refer to the last page, **Error! Reference source not found.**) within the safety segment and thus also contactors K3 and K4. The failure of a switching element in the emergency stop button or the safety door contact as well as a cross-circuit in their supply lines does not result in the failure of the emergency stop mechanism and is detected within the fault-reaction time.

After opening the safety door and the expiration of the delay time set in the EP-1922, the spring-operated interlock can be activated with the unlock button and the safety door can be opened. When the power supply is turned off, the safety door cannot be opened if the locking mechanism is engaged. We recommend using switches with mechanical unlocking capabilities.

The EP-19xx module switches the 24-V power supply for the following modules within the safety segment if:

- Emergency stop button is unlocked
- Safety door is closed
- Feedback circuit (NC contacts of K3 and K4) is closed

Contactors K3 and K4 are controlled by the PLC and can switch on as soon as the EP-19xx has switched on the 24-V supply. To reset the system when switching on the power simply press the reset button.

Figure 29: Example Application for Dual-channel Safety Door Monitoring with Automatic Reset and Controlled Shutdown and Emergency Stop

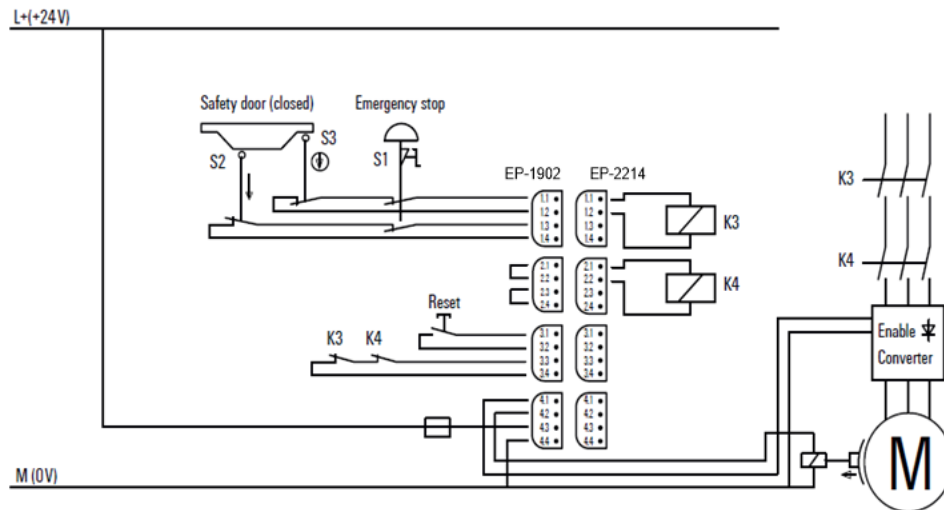

7.12 Cascading

Achievable safety rating	Cat. 4	DIN EN ISO 13849-1
	PLe	DIN EN ISO 13849-1
	SIL3	IEC 62061/61508
Notes	A shielded cable installation is necessary if the safely switched-off line (24 V OSSD on 4.2) runs outside the switch cabinet.	

Note: All example applications shown are proposals without warranty. In any case the operator must perform a safety review of the entire site.

The following shows the cascading of EP-19xx modules. When the safety door for the robot cell is opened in the example, the conveyor belt is also switched off at the same time. In contrast, switching off the conveyor belt (for example, with the cable-pull switch) does not automatically switch off the robot cell.

Multiple cascade levels and multiple EP-19xx modules can be used on a single level. Be aware that the triggering of an EP-19xx module immediately switches off the 24 V supply of all subsequent safe power feed modules. A delay of these modules is then no longer effective.

Figure 30: Example Application for Cascading

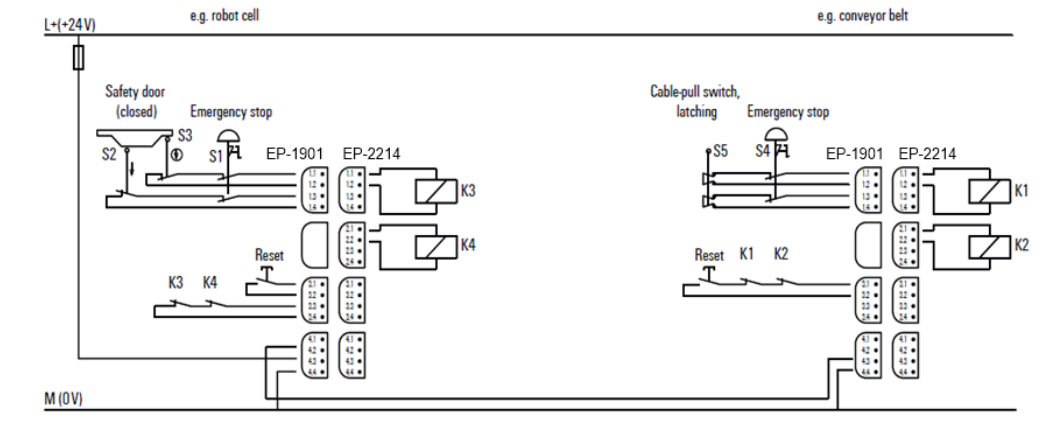

Chapter 8: LED Indicators and Troubleshooting



Attention

In the event of a malfunction occurring on a RSTi-EP station, carry out the following recommended measures. If the malfunction cannot be fixed, send the affected product to Emerson (refer to the section, **Error! Reference source not found.**).

Emerson does not assume any liability if the base or electronic module has been tampered with.

Module	LED	Status	Recommended action
EP-1901	Status LED	Red: <ul style="list-style-type: none"> - Module has not been snapped properly - Error in the supply voltage - Channel error 	<ul style="list-style-type: none"> - Check that the module has been snapped into place properly - Check supply voltage: <ol style="list-style-type: none"> 1. check +24 V input current path 2. check voltage on plug 4.3; in case of cascading 0 V might be properly, therefore this is not an error - Check channel error
		<ul style="list-style-type: none"> - Overload at the OSSD output level 	<ul style="list-style-type: none"> - Remove cross connection at OSSD
		<ul style="list-style-type: none"> - External feed-in recognised from field side 	<ul style="list-style-type: none"> - Measure voltage at OSSD (4.3) vs. GND (4.4) If a voltage is present, check the wiring. <p>Attention: safety hazard - Shut down the system and prevent it from switching on again</p>
		<ul style="list-style-type: none"> - Internal error detected 	<ul style="list-style-type: none"> - Module might have switched off caused by overtemperature; check the temperature inside the switch cabinet - Perform a cold start within 24 hours If the error has not been fixed, send the module to Emerson for a technical examination
		<ul style="list-style-type: none"> - Interruption in one of the two safety loops of a safety circuit for at least 3 seconds 	<ul style="list-style-type: none"> - Check safety circuit for interruptions if an interruption of the safety channel is not part of the application

Module	LED	Status	Recommended action
		- Cross connection between the safety loops for at least 3 seconds	- Check safety circuit for cross connections
	1.1	Off: Safety circuit 1 interrupted Yellow: Safety circuit 1 OK	Check safety circuit 1
	4.2	Off: OSSD not active Yellow: OSSD active, 24 V DC at output	
	4.3	Green: Feed-in voltage in valid range	
EP-1902, EP-1922	Status LED	Red: - Module has not been snapped properly - Error in the supply voltage Channel error	- Check that the module has been snapped into place properly - Check the supply voltage: 1. check +24 V input current path 2. check voltage on plug 4.3; in case of cascading 0 V might be properly, therefore this is not an error Check channel error
		Overload at the OSSD output level	Remove cross connection at OSSD
		External feed-in recognised from field side	- Measure voltage at OSSD (4.3) vs. GND (4.4). If a voltage is present, check the wiring. Attention: safety hazard! Shut down the system and prevent it from switching on again.
		Internal error detected	- Module might have switched off caused by overtemperature; check the temperature inside the switch cabinet - Perform a cold start within 24 hours. If the error has not been fixed, send the module to Inetlligent Platforms LLC for a technical examination.
		Interruption in one of the two safety loops of a safety circuit for at least 3 seconds.	Check safety circuit for interruptions if an interruption of the safety channel is not part of the application
		Cross connection between the safety loops for at least 3 seconds.	Check safety circuit for cross connections
	1.1	Off: Safety circuit 1 interrupted Yellow: Safety circuit 1 OK	Check safety circuit 1
	2.1	Off: Safety circuit 2 interrupted Yellow: Safety circuit 2 OK	Check safety circuit 2
	4.1 (DELAY only)	Off: SS1 not active Yellow: SS1 active, 24 V DC at output	

Module	LED	Status	Recommended action
	4.2	Off: OSSD not active Yellow: OSSD active, 24 V DC at output	
	4.3	Green: Feed-in voltage in valid range	

Chapter 9: Accessories and Replacement Parts

Order No.	Designation	Purpose
EP-8100	Swivel marker	Pivoting holder for module markers
EP-8101	Paper labels for swivel markers	Can be printed with laser printers
EP-8301	Termination kit	Set with two end brackets and one end plate
EP-8360	High density connector kit	High Density Connector signal connectors for EP-3368 and EP-3468 (8 connectors per package)
EP-8150	Snap-In-Module Marker	Module Marker

9.1 Replacement Parts

Figure 31: Replacement Parts

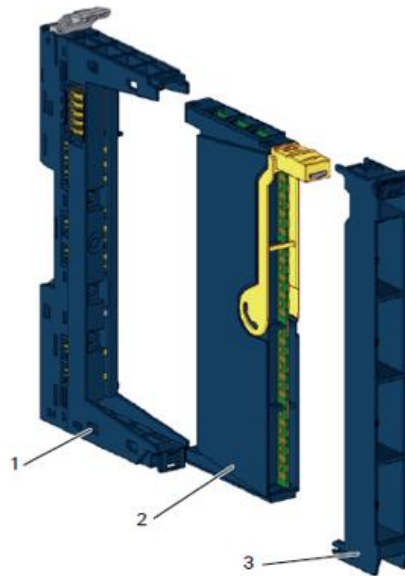

1. Base module
2. Electronic unit
3. Plug-in unit

Replacement Parts for Modules

Module/Order No	Base Module
EP-1901	EP-8300
EP-1902	EP-8300
EP-1922	EP-8300

Appendix A: Checklist for Use of EP-19xx Modules

Checklist for use of EP-19xx Modules
Sheet 1/3: Planning

Equipment type / equipment ID	
Version: HW/FW	Date:
Reviewer 1:	Reviewer 2:
Notes:	

No	Requirement (mandatory)	Yes	Remark
1	The corresponding manual was consulted during planning.		
2	The sensors/control devices are approved for connection to the module.		
3	The power supply was planned as per the safety extra-low voltage guidelines in accordance with PELV or SELV.		
4	The module was externally fused according to the guidelines in the manual.		
5	Measures to prevent simple manipulations have been planned.		
6	Measures against plug mix-ups have been planned.		
7	The requirements for the sensors and installation of cables correspond to the applicable safety standards (SIL, Cat., PL) and the planned implementation takes these standards into consideration.		
8	The guidelines for per-channel configuration have been defined.		
9	The intentional starting up of potentially hazardous processes is only possible while looking into the danger zone at the same time.		
10	If the installation requires exclusions of faults: the measures have been realized.		
11	The planned use corresponds to the intended use.		
12	The environmental conditions meet the guidelines that are specified in the technical data.		
	Requirement (optional)	Yes/No	Remark
13	The accessories to be used were selected according to the order data in the manual.		
14	The guidelines for installation and electrical set-up were defined and handed over to the departments performing the work.		
15	The guidelines for commissioning were defined and handed over to the departments performing the work.		
Date / Signature of Reviewer 1:		Date / Signature of Reviewer 2:	

Checklist for use of EP-19xx Modules
Sheet 2/3: Assembly and electrical installation

Equipment type / equipment ID	
Version: HW/FW	Date:
Reviewer 1:	Reviewer 2:
Notes:	

No.	Requirement (mandatory)	Yes	Remark
1	Installation was carried out in accordance with the guidelines from the planning stage and/or the manual.		
2	The safety module(s) was(were) installed in a switch cabinet (IP 54).		
3	All conductor cross-sections meet the guidelines.		
Date / Signature of Reviewer 1:		Date / Signature of Reviewer 2:	

Checklist for use of EP-19xx Modules
Sheet 3/3: Commissioning and configuration

Equipment type / equipment ID	
Version: HW/FW	Date:
Reviewer 1:	Reviewer 2:
Notes:	

No.	Requirement (mandatory)	Yes	Remark
1	During commissioning, the intentional starting up of potentially hazardous processes is only possible while looking into the danger zone at the same time.		
2	Commissioning is carried out according to the guidelines from the planning stage and/or the manual.		
3	All inputs were configured.		
	Requirement (optional)	Yes/No	Remark
4	The safety clearances to be maintained are measured according to the implemented reaction and delay times.		
Date / Signature of Reviewer 1:		Date / Signature of Reviewer 2:	

Technical Support & Contact Information:

Home link: <http://www.Emerson.com/Industrial-Automation-Controls>

Knowledge Base: <https://www.emerson.com/Industrial-Automation-Controls/support>

Note: If the product is purchased through an Authorized Channel Partner, please contact the seller directly for any support.

Emerson reserves the right to modify or improve the designs or specifications of the products mentioned in this manual at any time without notice. Emerson does not assume responsibility for the selection, use or maintenance of any product. Responsibility for proper selection, use and maintenance of any Emerson product remains solely with the purchaser.

© 2019 Emerson. All rights reserved.

Emerson Terms and Conditions of Sale are available upon request. The Emerson logo is a trademark and service mark of Emerson Electric Co. All other marks are the property of their respective owners.

